



www.greenlee.com

LS50FLEXCFB



Serialnumber

HE.18064_B © 08/2017 R&D-2



Greenlee • 4455 Boeing Drive • Rockford • IL 61109-2988 USA





LS50FLEXCFB

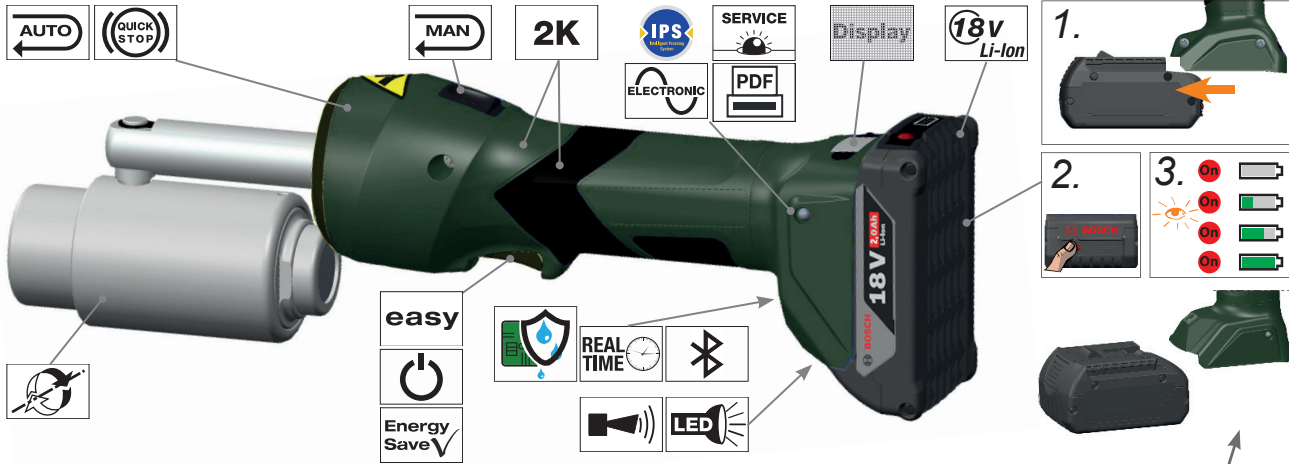

datecode

Year	Code	Month	Code	Month	Code
2018	M	Jan.	N	July	V
2019	N	Feb.	P	Aug.	W
2020	P	Mar.	Q	Sept.	X
2021	Q	Apr.	R	Oct.	Y
2022	R	May	S	Nov.	Z
2023	S	June	T	Dec.	1



batch# e.g. 304711
datecode e.g. P = 2020; R = April
consecutive# e.g. „142“ = tool # 142

304711
PR
142

Klauke
Auf dem Knapp 46
D-42855
Remscheid





LS50FLEXCFB

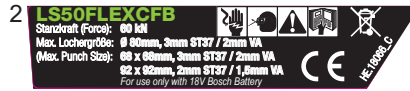
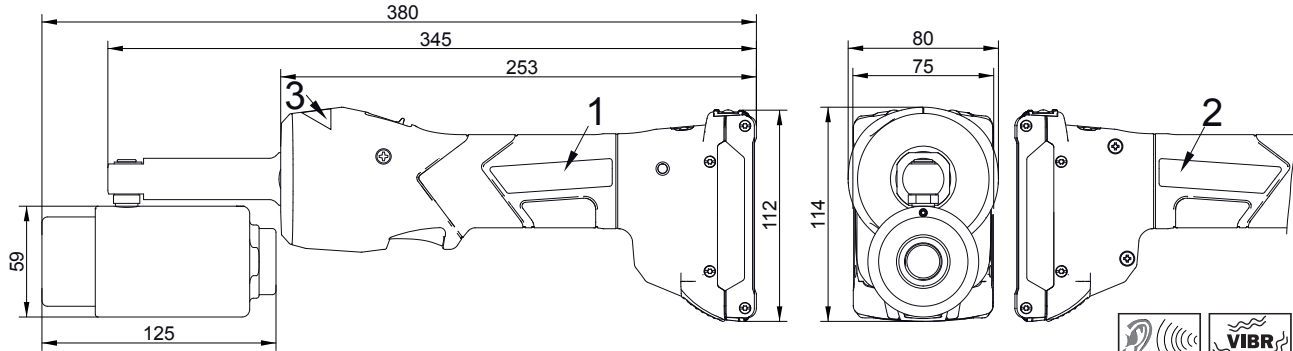

 <70dB	 <2,5m/s ²
 +40°C -10°C	 BIO
 2,1 kg	 6 ton

! WARNING

Read all safety warnings, instructions, illustrations and specifications provided with this power tool.

Failure to follow all instructions listed below may result in electric shock, fire and/or serious injury.

Save all warnings and instructions for future reference.





LS50FLEXCFB



Use tool only with 18V Bosch Battery

BOSCH
 #1 609 92A 19R
 #1 609 92A 0F3

Li-ion

Loading Full

1.

2.

3.

Ladegerät	GAL		GAL 1880 CV	
Sachnummer	2 607 225 ...		2 607 225 9..	
	2 607 226 ...		2 607 226 0..	
Akku-Ladespannung (auto-matische Spannungserkennung) V $\overline{\text{~}}$		14,4 – 36		14,4 – 18
Ladestrom A		8,0		8,0
Zulässiger Ladetemperaturbereich °C		0 – 45		0 – 45
Ladezeit bei Akku-Kapazität, ca.		(80%) 100%	(80%) 100%	
- 1,3 Ah	min	(10) 25	(10) 25	
- 1,5 Ah	min	(10) 25	(10) 25	
- 2,0 Ah RALB1__ (36Wh)	min	(15) 30	(15) 30	
- 2,6 Ah	min	(15) 30	(15) 30	
- 3,0 Ah	min	(20) 35	(20) 35	
- 4,0 Ah	min	(25) 35	(25) 35	
- 5,0 Ah RALB2__ (90Wh)	min	(35) 45	(35) 45	
- 6,0 Ah	min	(35) 50	(35) 50	
Anzahl der Akkuzellen		4 – 30		4 – 10
Gewicht entsprechend EPTA-Procedure 01:2014	kg	0,9		0,7
Schutzklasse		<input type="checkbox"/> / II		<input type="checkbox"/> / II



Alle Bedienungsanleitungen auch unter www.klauke.de abrufbar
All manuals are also available on www.Klauke.com

WORK **SERVICE** **DON'T DO** **General safety rules**



LS50FLEXCFB

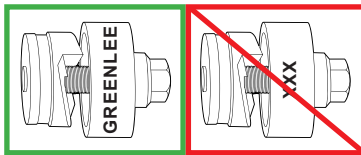
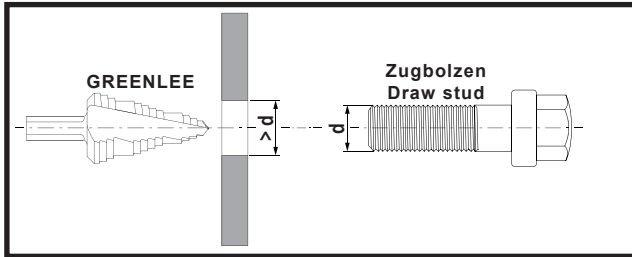
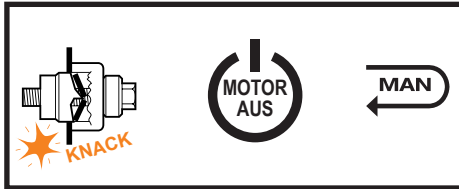
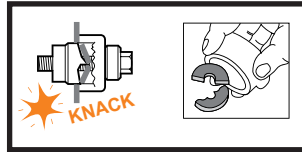

Klauke ASC
 Authorised Service Center

www.klauke.com
 ++49 +2191-9070

GERMANY
 Gustav Klauke GmbH
 Ms. Yvonne Braemeier (national)
 Mr. Jens Berteit (international)
 Auf dem Knapp 46
 42855 Remscheid
 ☎ 0049-2191/907-222
 📠 0049-2191/907-243
 ✉ klauke-service@emerson.com



Material	Blechstärke	Typ
St 37	2,5 mm	Rundlocher bis Ø 82 mm (Standard) Quadratlocher 92 mm x 92 mm Rechtecklocher 46 mm x 92 mm
	3,0 mm	Rundlocher bis Ø 63,5 mm (Slug Buster) Quadratlocher 68 mm x 68 mm
	3,5 mm	Rundlocher bis Ø 63,5 mm (Standard Locher)
Rostfrei (V2A)	3,0 mm	Rundlocher bis Ø 63,5 mm (VA-Locher)
VA	1,5 mm	Rechtecklocher 46 mm x 92 mm Quadratlocher 68 mm x 68 mm





LS50FLEXCFB

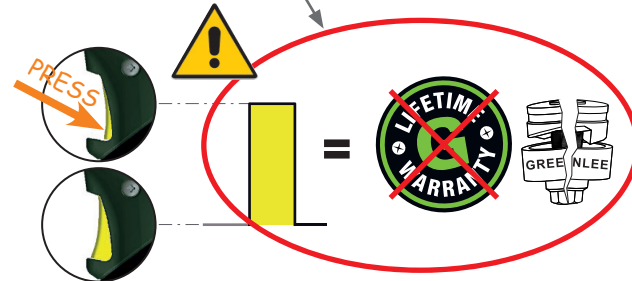
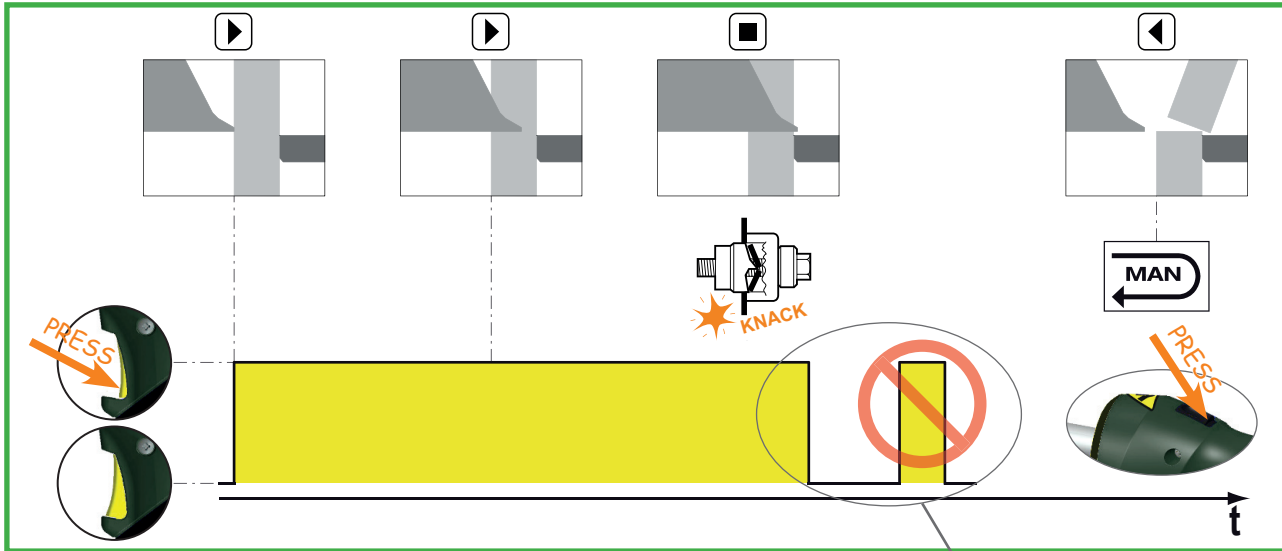

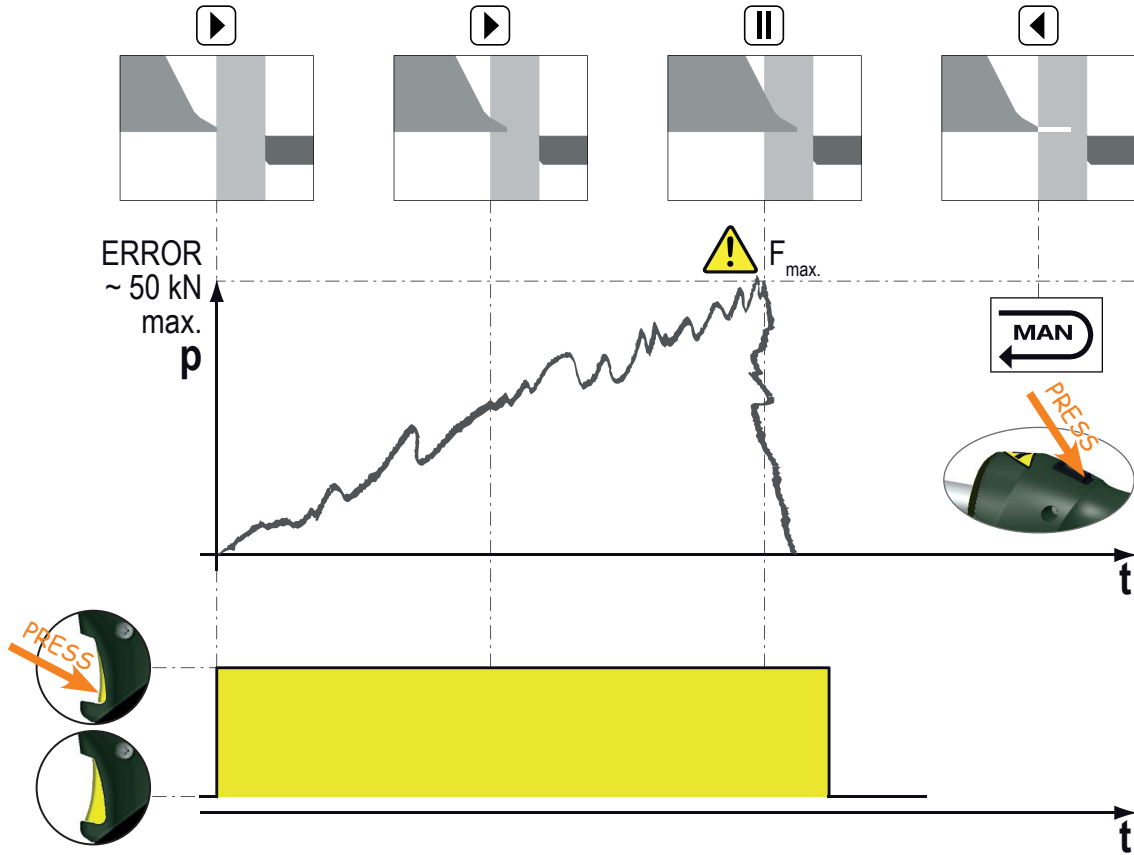

**Kapazitätsangaben mit Zugbolzenauswahltabelle/Capacity with draw stud selection guide**

Weiche Stähle/Mild steel					
Standard und Slug-Buster Lochstanzen/Zugbolzen/Standard and Slug-Buster punches/Draw studs					
Stahldicke Steel gauge	Lochgrößen/Pipe size				
	12,7 mm	19 - 31,75 mm	38,1 - 76,2 mm	88,9 - 127 mm	152,4 mm
3 mm (10 ga.)	A, E	B, E	B	--	--
2,5 mm (12 ga.)				B, F	B, F
2 mm (14 ga.)					

Edelstahl/ Stainless steel		
Slug-splitter Lochstanzen/Zugbolzen Slug-splitter punches/Draw studs		
Stahldicke Steel gauge	Lochgrößen/Pipe size	
	12,7 mm	19 - 50,8 mm
3 mm (10 ga.)	C, E	D, E

Weiche Stähle/Mild steel	
Electronic connector punches Electronic connector punches	
Stahldicke/Steel gauge	RS232, 229, 231, 234, 238
1,5 mm (16 ga.)	33967 Adapter, 1924AA Distanzstück 33967 adapter, 1924AA spacer

Schlüssel/Key

Teil Item	Zugbolzen und Stanzzubehör/Draw stud and hardware	
	Katalog Nr./Catalog N°	Beschreibung/Description
A	20963	9,5 mm x 200,66 mm Zugbolzen/draw stud
B	31872	19 mm x 102,36 mm Zugbolzen/draw stud
C	29451	11,11 mm x 107,95 mm Zugbolzen (Edelstahl)/draw stud (Stainless steel)
D	29452	19 mm x 139,7 mm Zugbolzen (Edelstahl)/draw stud (Stainless steel)
E	1924AA	22,22 mm Distanzstück/spacer
F	1557AA	28,58 mm x 76,2 mm Stanzhülse/ punch sleeve



UPC # 60118

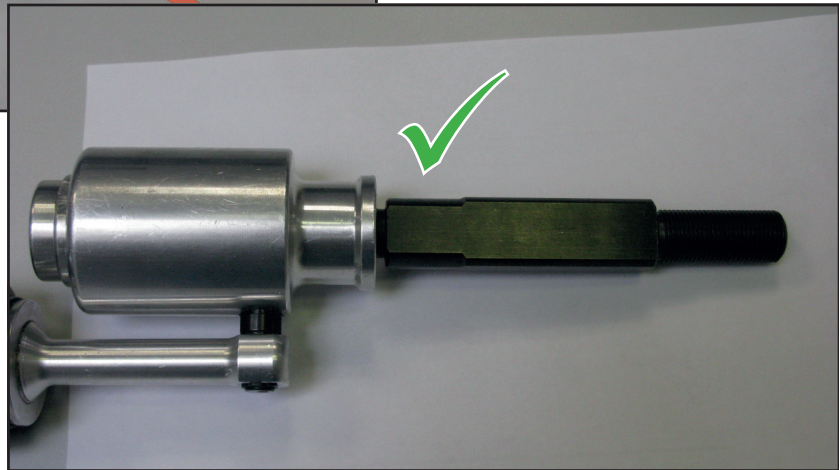
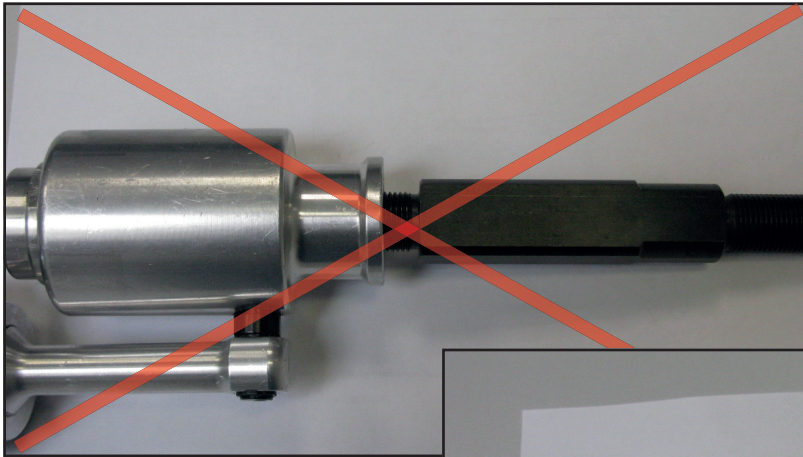

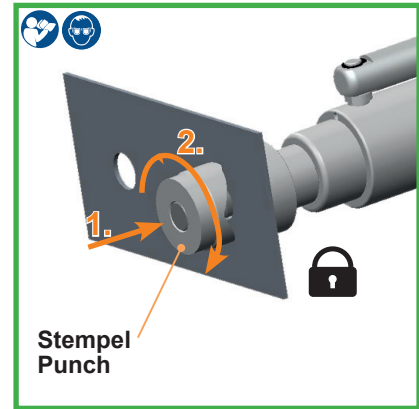
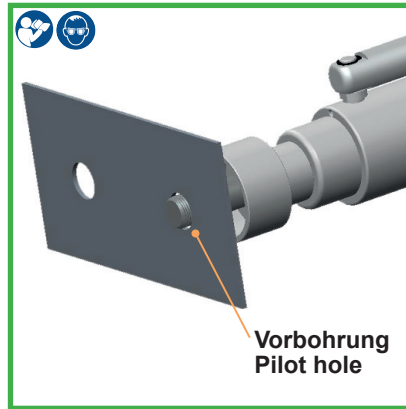
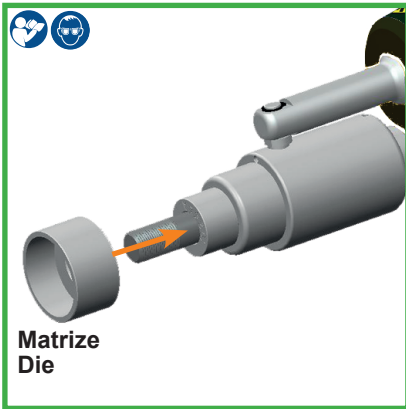
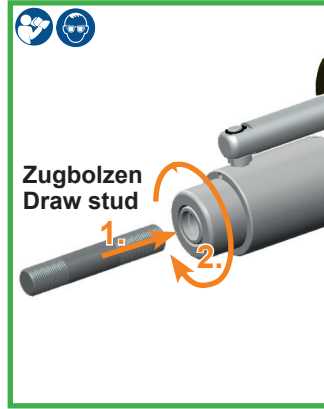
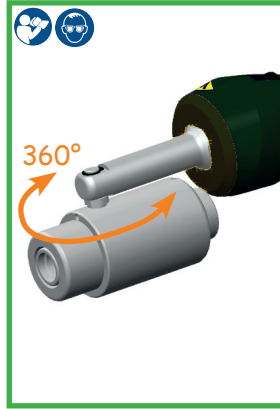

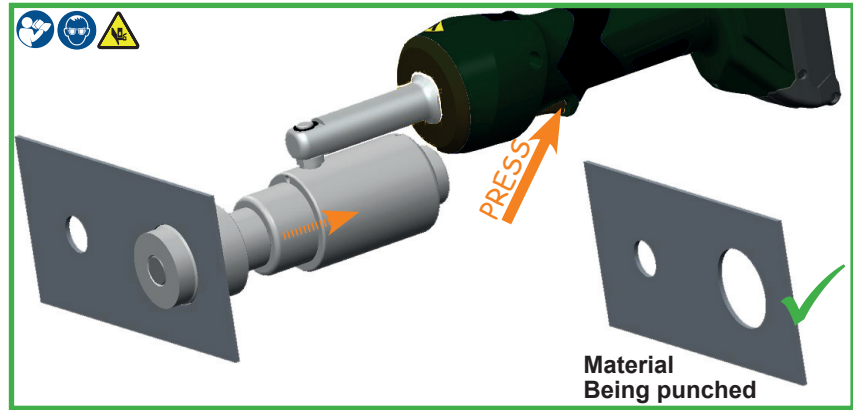
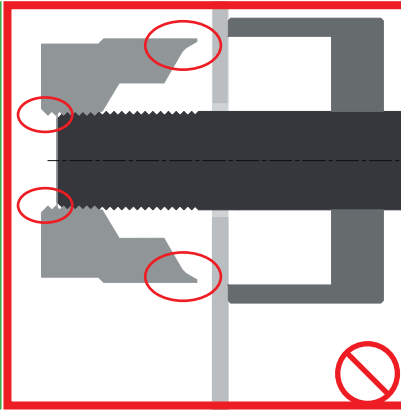
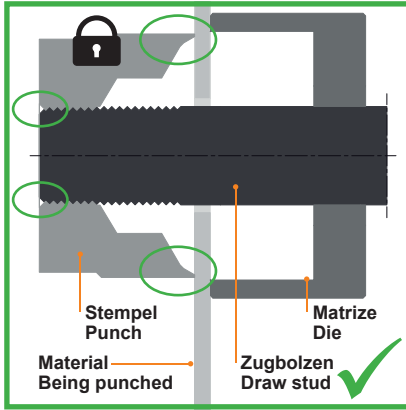

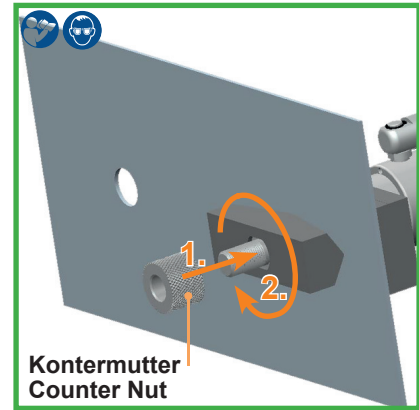
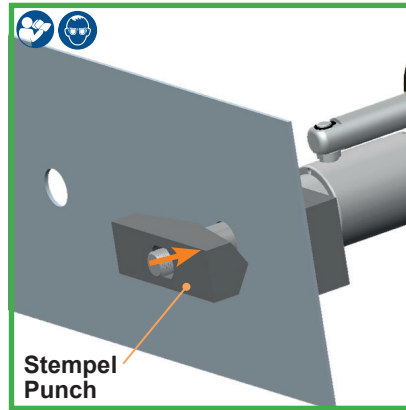
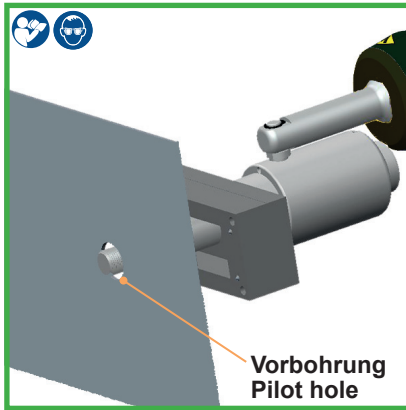
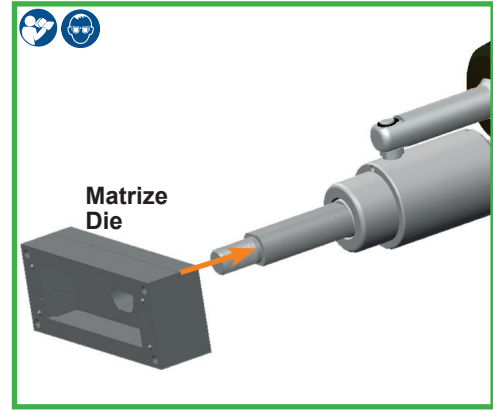
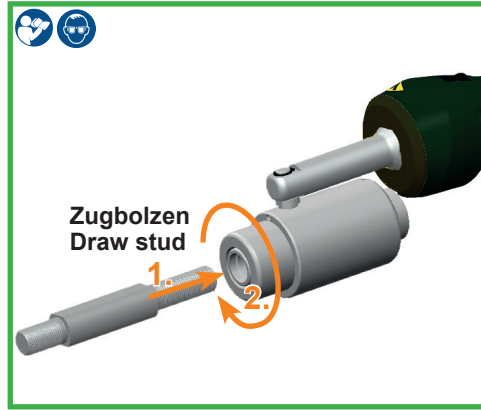



LS50FLEXCFB

mit Kontermutter
with Counter nut

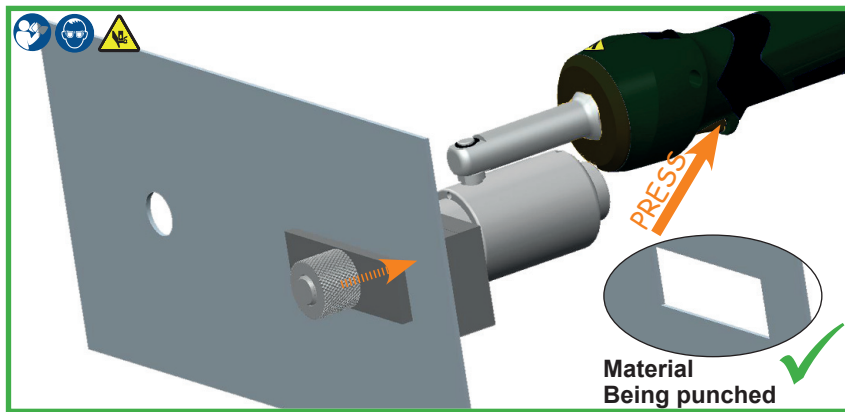
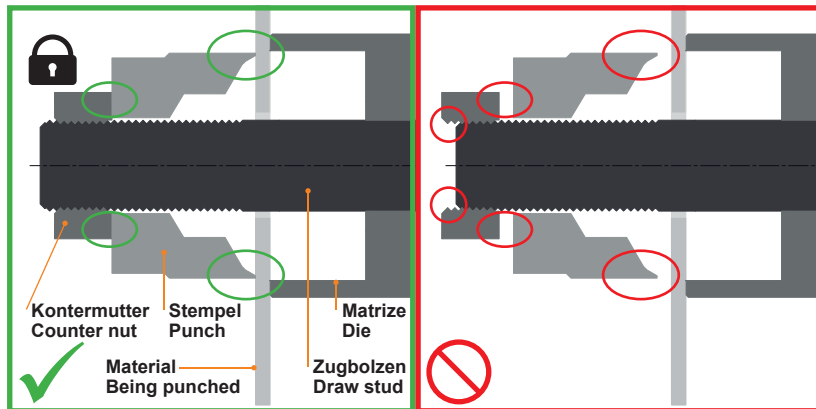
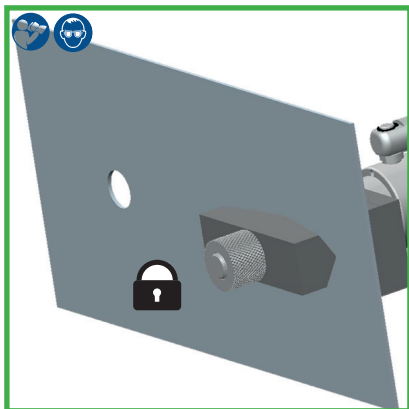



LS50FLEXCFB

mit Schnellspannmutter
with Speed Punch Lock

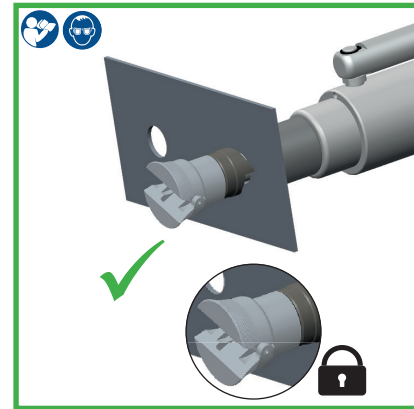
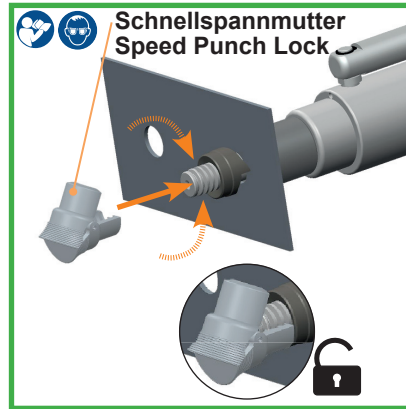
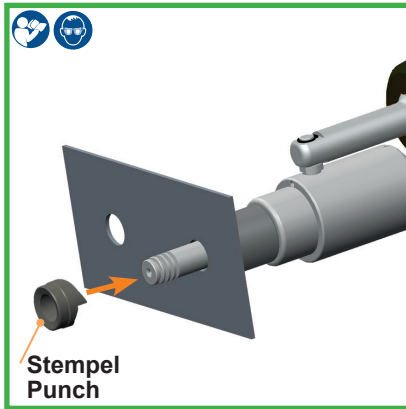
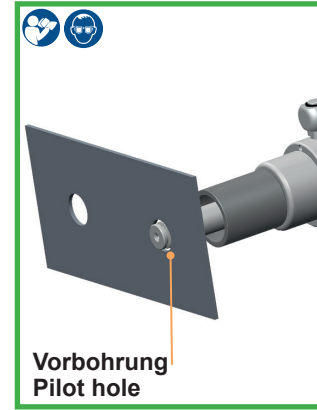
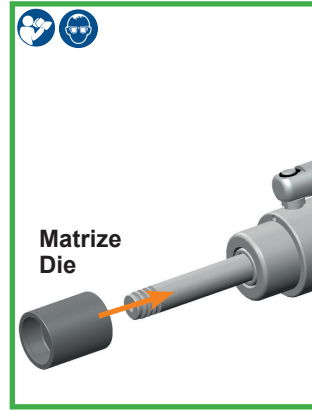
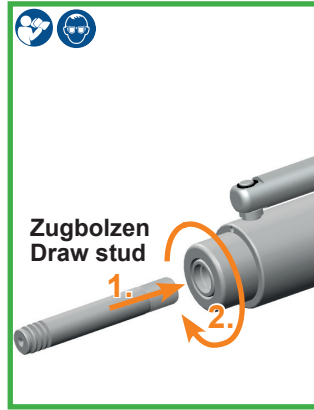



LS50FLEXCFB

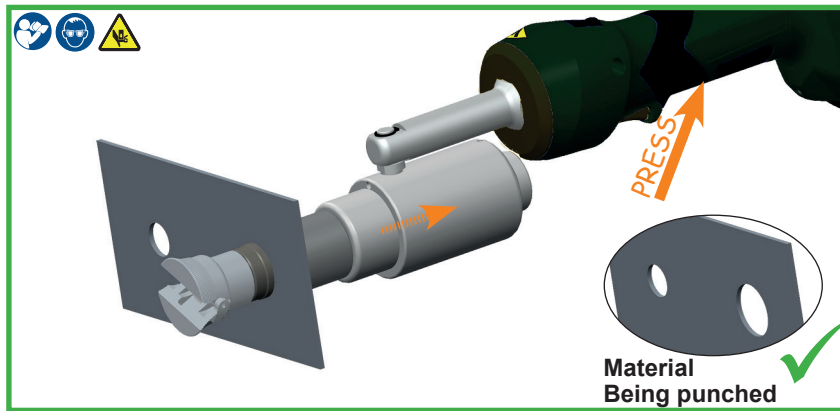
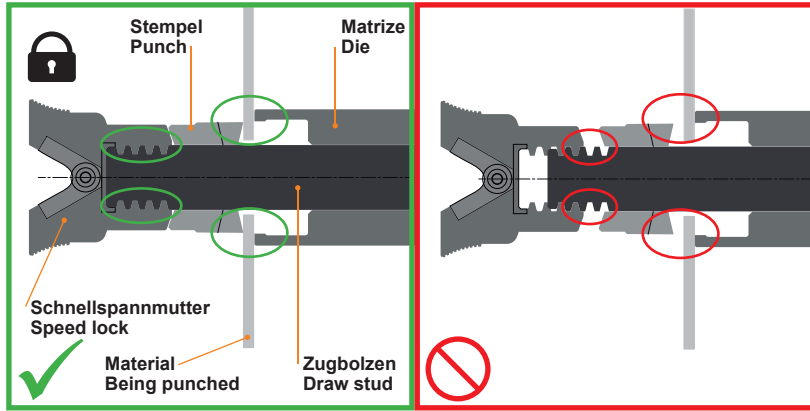



LS50FLEXCFB

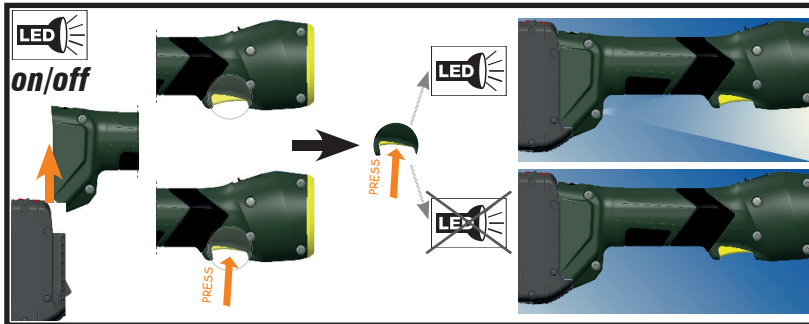
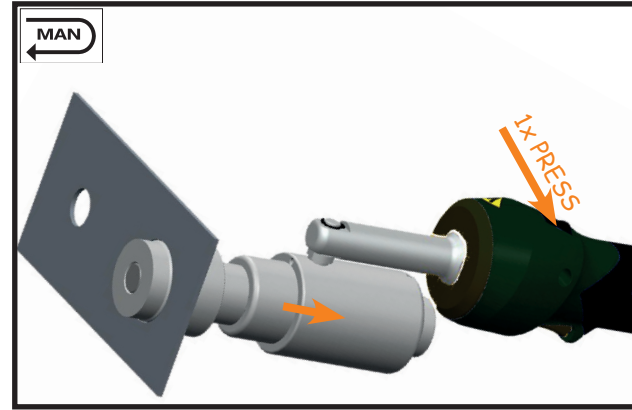
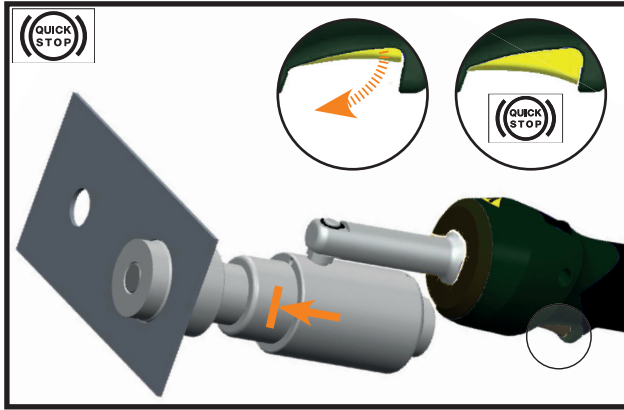



1			
2		Klauke®	
		ERROR CODE: ****	Error code *1
3		BT P 3 bar P̂ 3 bar	Bluetooth (if connected) Battery charging level Current pressure Pressure max. *2
4a		USER 3: RD3 Doppelklick	Doubleclick
4b	 3 sec.	USER SELECT 3: RD3 Einfachklick	Singleclick enter menu
4c		USER SELECT: RD3 Doppelklick	Doubleclick select
4d		USER SELECT: RD3 Doppelklick	Doubleclick confirmed
5		NEXT SERVICE: 9826 0Ps	Cycles (until next service)
6		TOTAL: t = 0.07 h Q = 21.12 Ah n = 174	Since manufacturing: operating hours Capacity # crimps
7		RETURN	

- *1 Error codes:
- Overcurrent fuse
 - Overcurrent comparator
 - Overheat board
 - Overheat battery
 - Battery empty, operation stop
 - Faulty crimp motor in operation
 - Faulty crimp motor not in operation
 - Low battery
 - Battery empty
 - RTC battery low
 - Tool deactivated
 - Service necessary
 - RTC not found
 - BT unit not found
 - Mobile unit not found
 - Pressure sensor not found
 - Burst pressure exceeded
 - Battery temperature too low
-
- Überstrom durch Überstromsicherung
 - Überstrom durch Komparator
 - Boardtemperatur zu hoch
 - Akkutemperatur zu hoch
 - Akkuspannung während der Operation zu gering
 - Fehlpressung bei laufendem Motor
 - Fehlpressung bei stehendem Motor
 - Niedrige Akkuspannung
 - Akku leer
 - RTC-Batterie leer
 - Werkzeug deaktiviert
 - Service nötig
 - RTC nicht verfügbar
 - BT-Modul nicht verfügbar
 - GSM/CDMA nicht verfügbar
 - Drucksensor nicht verfügbar
 - Berstdruck überschritten
 - Akkutemperatur zu gering

*2 (2Hz)





Klauke i-press® Software

▶ www.klauke.com/connectivity



Klauke i-press® App

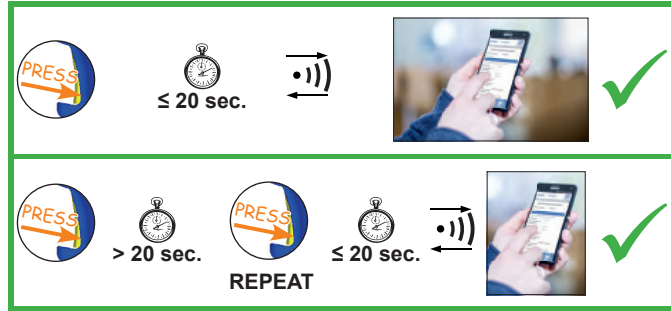



LS50FLEXCFB



BEFORE WORK

DIN EN 50110

2 years
Warranty

World wide
Tool
Service

- 1.
- 2.
- 3.



once a year

Klauke ASC
Authorised Service Center

3 years or
10.000 operations

OLD
PART
REPLACEMENT
SAFETY
NEW

2 years
Warranty

World wide
Tool
Service

Klauke ASC
Authorised Service Center

WEEE
2012/19/EU

klauke-weee-abholung@emerson.com

Klauke ASC
Authorised Service Center





			Wann/When/Quand/Quando/ cuándo/Wanneer/Когда/это происходит/Kiedy/quando	Warum/Why/Pourquoi/Porquê/ ¿por qué?/Waarom/Причина/ Dlaczego/Perché
 20 sec			nach Arbeitsvorgang after working cycle après opération de travail Después del proceso de trabajo após o processo de trabalho na bedrijfscyclus после цикла опрессовки po zakończeniu pracy dopo il processo di lavoro	
 20 sec/2Hz			nach Arbeitsvorgang after working cycle après opération de travail Después del proceso de trabajo após o processo de trabalho na bedrijfscyclus после цикла опрессовки po zakończeniu pracy dopo il processo di lavoro	 Klauke ASC Authorized Service Center
 20 sec/5Hz			während der Übertemperatur while exceeding the temp. limit pendant surchauffe en caso de temperatura excesiva durante a temperatura excessiva tijdens te hoge temperatuur при высокой температуре внутри корпуса przy przegrzaniu superando il limite di temperatura	Werkzeug zu heiß Unit too hot outil surchauffé Herramienta demasiado caliente ferramenta demasiado quente gereedschap te heet Перегрев инструмента urządzenie za gorące Utensile troppo caldo





Lochen mit
12,7 mm (ø 22,5 mm)
Rundlochern

Punching with
12,7 mm (ø 22.5 mm)
pipe size

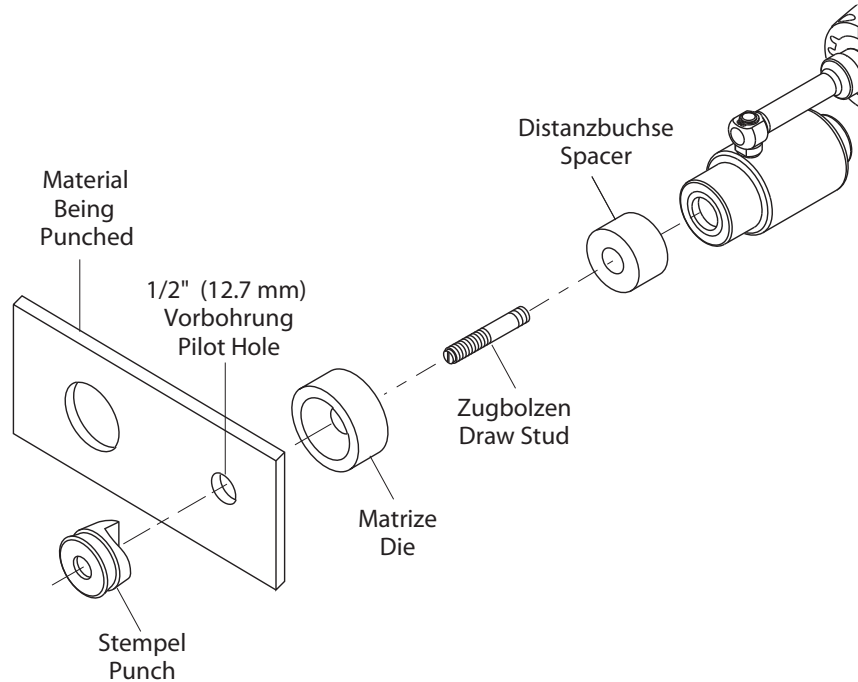



Lochen mit
19 mm (ø 28,3 mm)
bis 31,75 mm (ø 43,2 mm)
Rundlochern

Punching with
19 mm (ø 28.3 mm)
to 31,75 mm (ø 43.2 mm)
pipe sizes

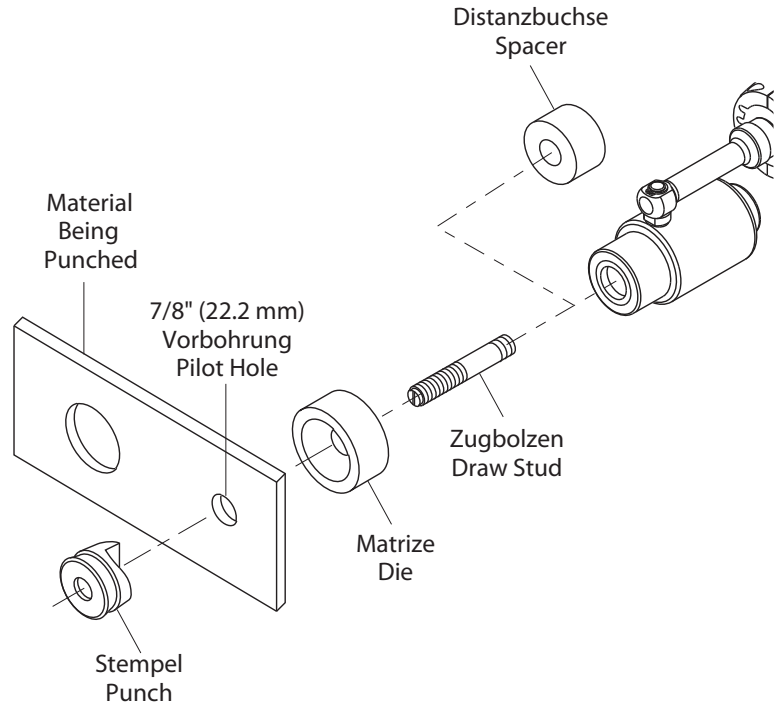



Lochen mit
38,1 mm (ø 49,6 mm)
bis 76,2 mm (ø 89,9 mm)
Rundlochern

Punching with
38,1 mm (ø 49.6 mm)
to 76,2 mm (ø 89.9 mm)
pipe sizes

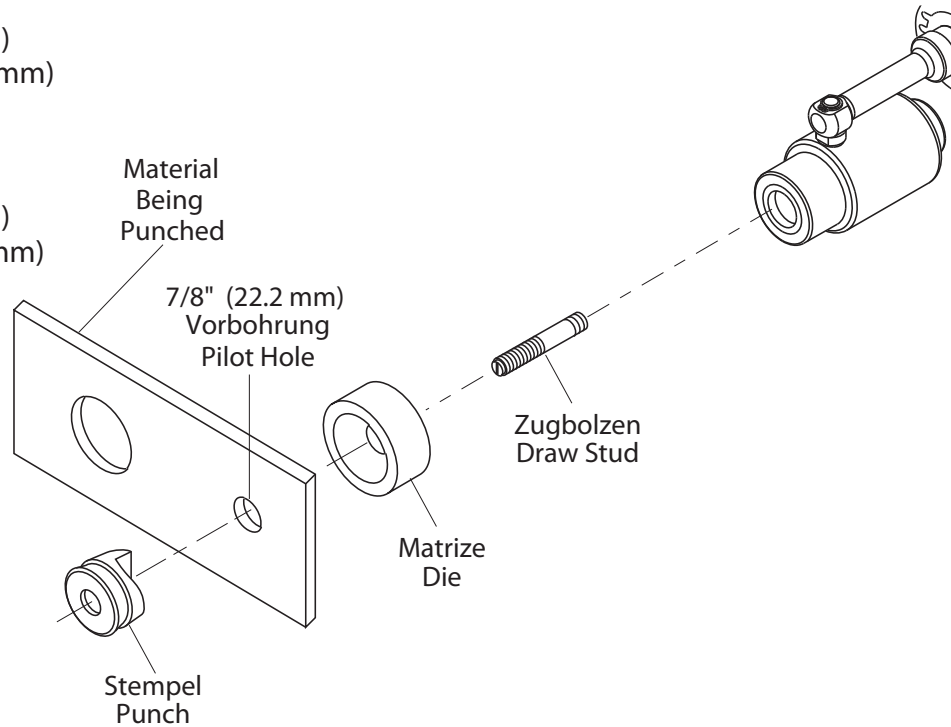



Lochen mit
88,9 mm (ø 102,7 mm)
bis 152,4 mm (ø 161,9 mm)
Rundlochern

Punching with
88,9 mm (ø 102.7 mm)
to 152,4 mm (ø 161.9 mm)
pipe sizes

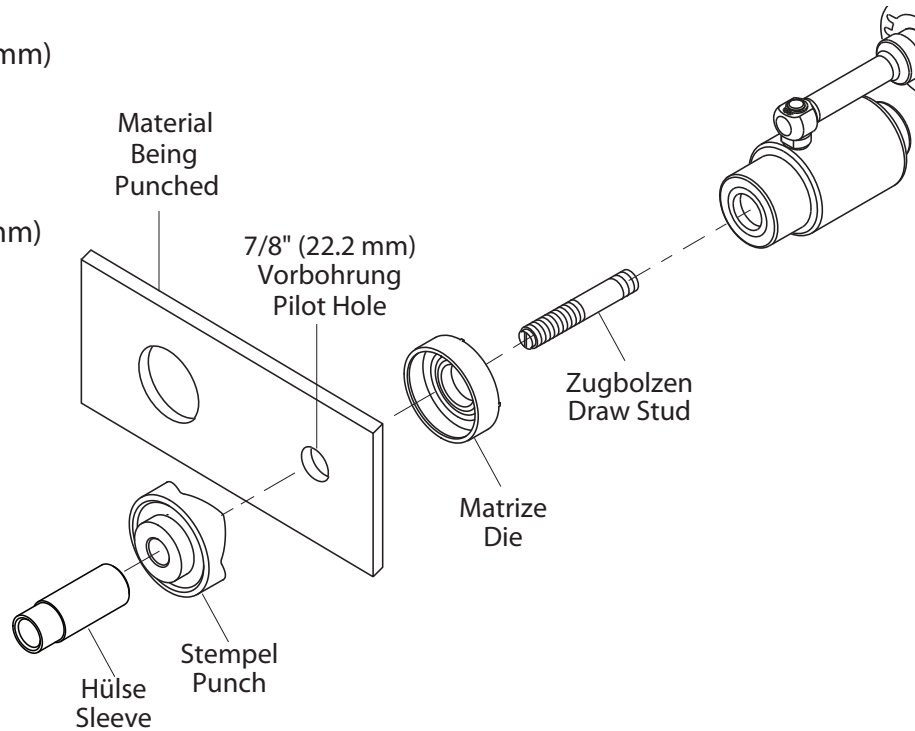



Lochen mit
12,7 mm Quadrat bzw.
11,1 mm x 22,2 mm Rechteck

Punching with
12,7 mm x 12,7 mm square respectively
11,1 mm x 22,2 mm rectangular

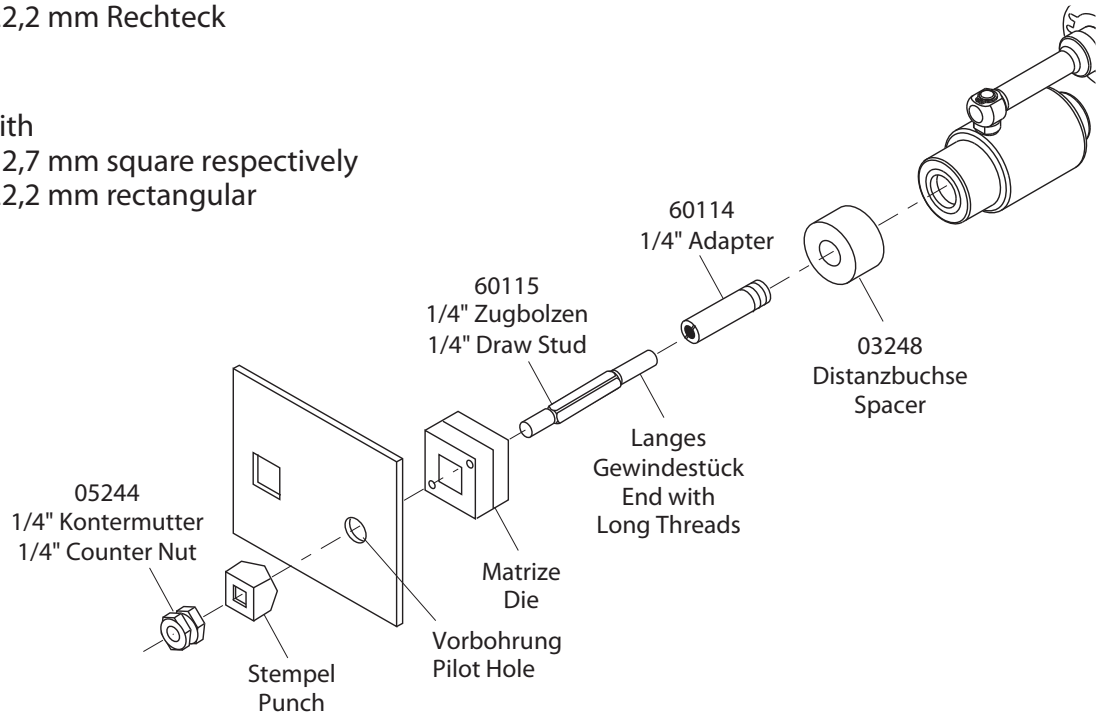



Lochen mit
15,9 mm bis 24,0 mm Quadrat bzw.
17,0 mm x 19,0 mm Rechteck

Punching with
15,9 mm through 24,0 mm square respectively
17,0 mm x 19,0 mm rectangular

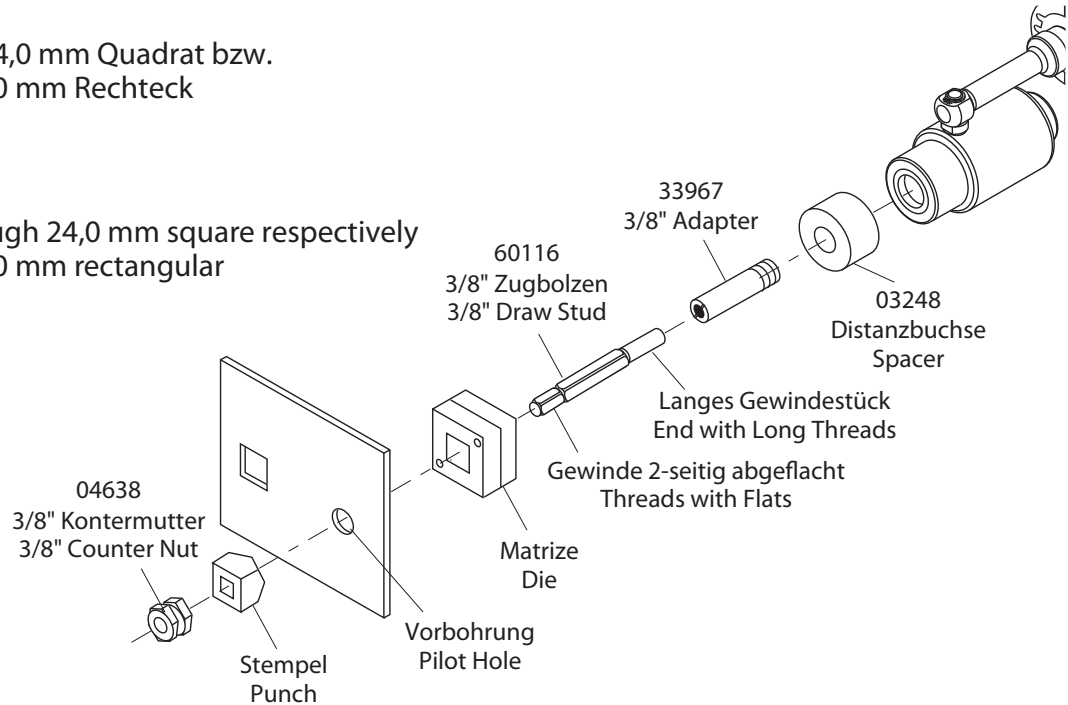



Lochen mit
25,4 mm Quadrat bzw.
19,1 mm x 29,0 mm
bis 31,8 mm x 35,1 mm Rechteck

Punching with
25,4 mm square respectively
19,1 mm x 29,0 mm through
31,8 mm x 35,1 mm rectangular

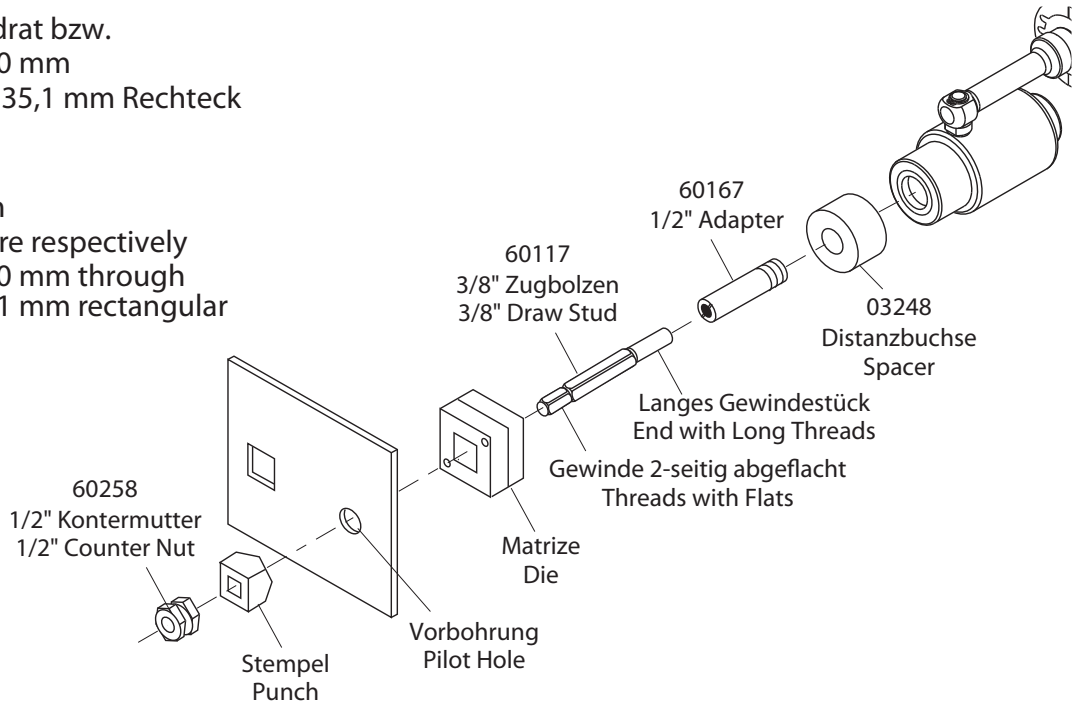



Lochen mit

46,0 mm bis 68,0 mm Quadrat bzw.

33,3 mm x 66,7 mm Rechteck

bis 35,0 mm x 65,0 mm Rechteck

Punching with

46,0 mm bis 68,0 mm square respectively

33,3 mm x 66,7 mm rectangular

through 35,0 mm x 65,0 mm rectangular

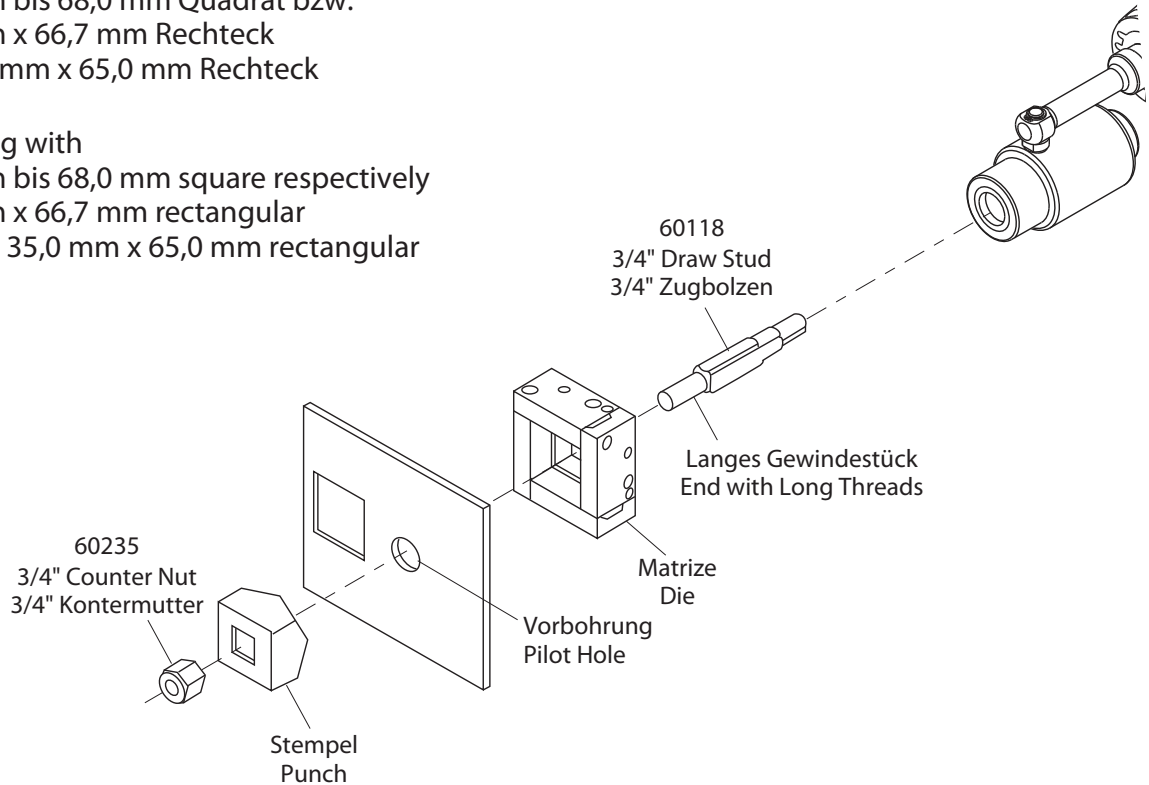



Lochen mit
Doppel-D-Lochern

Punching with
"D", Double "D",
and Key sizes

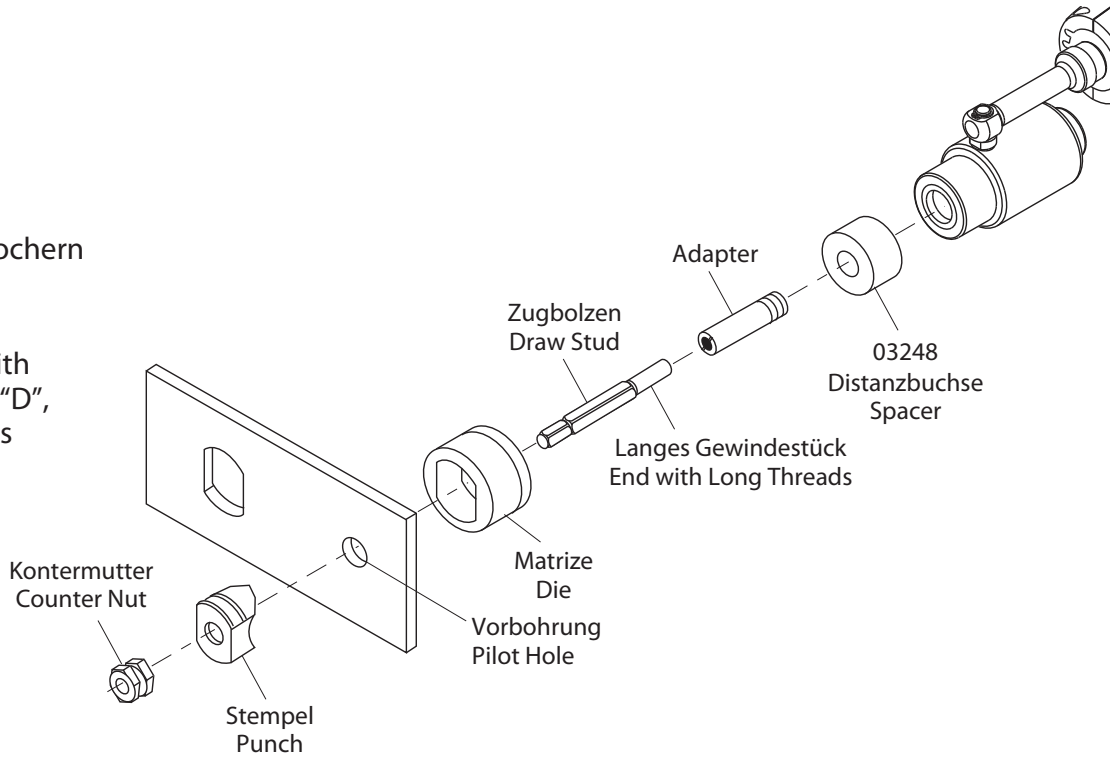



Lochen mit
Sub-Min-D-Lochern

Punching with
Electronic Connector
Panel Punches

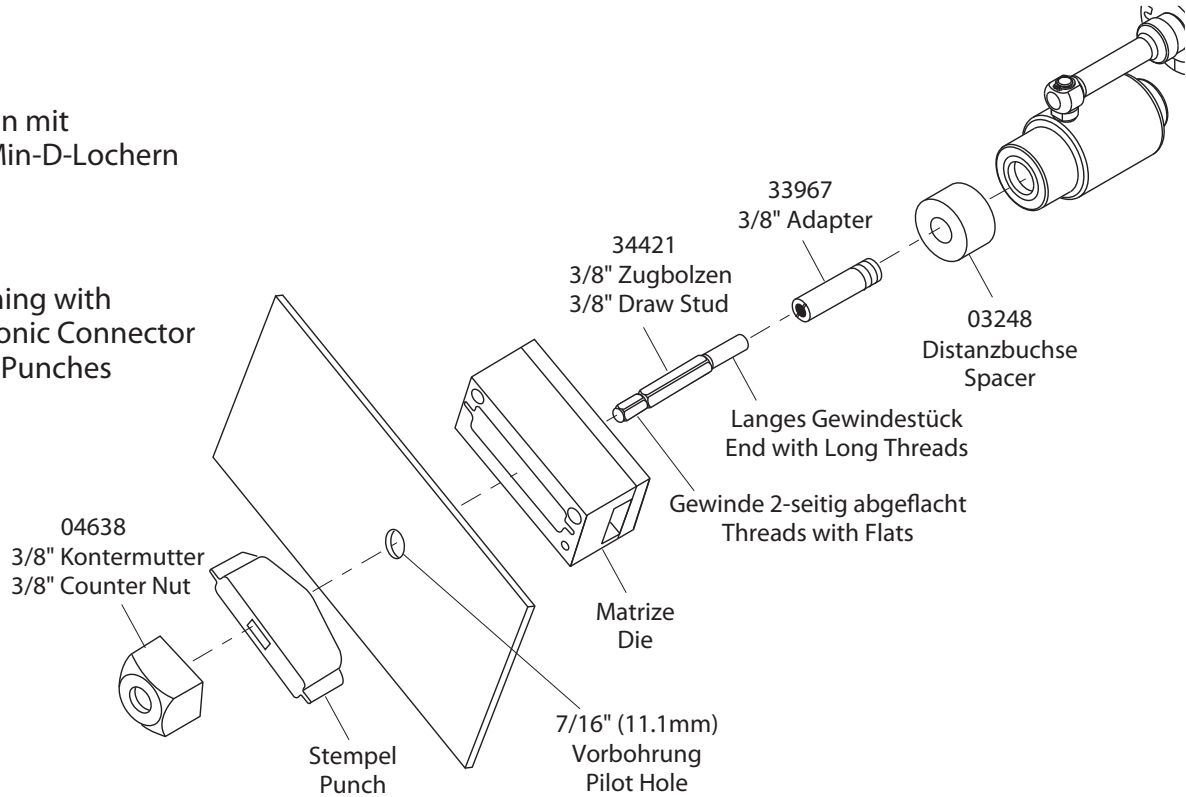

Handgeführtes batteriebetriebenes Elektrowerkzeug Typ LS50FLEXCFB

Klauke[®]

- (D) CE-17 - Konformitätserklärung. Wir erklären in alleiniger Verantwortlichkeit, daß dieses Produkt mit den folgenden Normen oder normativen Dokumenten übereinstimmt: EN 62841-1, EN ISO 12100, EN ISO 13857, EN 349, EN 28662-1, EN 61000-6-3, EN 61000-6-2, EN 60529, EN 1037 gemäß den Bestimmungen der Richtlinien 2006/42/EG, 2014/30/EU, 2011/65/EU
- (GB) CE-17 - Declaration of conformity. We declare under our sole responsibility that this product is in conformity with the following standards or normative documents: EN 62841-1, EN ISO 12100, EN ISO 13857, EN 349, EN 28662-1, EN 61000-6-3, EN 61000-6-2, EN 60529, EN 1037 in accordance with the regulations of directives 2006/42/EG, 2014/30/EU, 2011/65/EU
- (F) CE-17 - Déclaration de conformité. Nous déclarons sous notre seule responsabilité que ce produit est en conformité avec les normes ou documents normatifs suivants: EN 62841-1, EN ISO 12100, EN ISO 13857, EN 349, EN 28662-1, EN 61000-6-3, EN 61000-6-2, EN 60529, EN 1037 conformément aux réglementations des directives 2006/42/EG, 2014/30/EU, 2011/65/EU
- (E) CE-17 - Declaración de conformidad. Declaramos bajo nuestra sola responsabilidad que este producto está en conformidad con las normas o documentos normativos siguientes: EN 62841-1, EN ISO 12100, EN ISO 13857, EN 349, EN 28662-1, EN 61000-6-3, EN 61000-6-2, EN 60529, EN 1037 de acuerdo con las regulaciones de las directivas 2006/42/EG, 2014/30/EU, 2011/65/EU
- (I) CE-17 - Dichiarazione di conformità. Dichiariamo sotto la nostra esclusiva responsabilità che questo prodotto è conforme alle seguenti norme e documenti normativi: EN 62841-1, EN ISO 12100, EN ISO 13857, EN 349, EN 28662-1, EN 61000-6-3, EN 61000-6-2, EN 60529, EN 1037 conformemente alle disposizioni delle direttive 2006/42/EG, 2014/30/EU, 2011/65/EU
- (P) CE-17 - Declaração de conformidade. Declaramos sob nossa exclusiva responsabilidade que este produto cumpre as seguintes normas ou documentos normativos: EN 62841-1, EN ISO 12100, EN ISO 13857, EN 349, EN 28662-1, EN 61000-6-3, EN 61000-6-2, EN 60529, EN 1037 conforme as disposições das directivas 2006/42/EG, 2014/30/EU, 2011/65/EU
- (NL) CE-17 - Konformiteitsverklaring. Wij verklaren en wij stellen ons er alleen voor verantwoordelijk dat dit product voldoet aan de volgende normen of normatieve documenten: EN 62841-1, EN ISO 12100, EN ISO 13857, EN 349, EN 28662-1, EN 61000-6-3, EN 61000-6-2, EN 60529, EN 1037 overeenkomstig de bepalingen van de richtlijnen 2006/42/EG, 2014/30/EU, 2011/65/EU
- (GR) CE-17 - ΔΗΛΩΣΗ ΣΥΜΜΟΡΦΩΣΗΣ Με αναληψη συλλογικης δηλωνομε: οτι το πορον προιον συμφωνα με τα παρακατω ποστυπα και με τα ηρωτηα που αναφερονται στα σχετικα εγγραφα. EN 62841-1, EN ISO 12100, EN ISO 13857, EN 349, EN 28662-1, EN 61000-6-3, EN 61000-6-2, EN 60529, EN 1037 συμφωνα με τοχς κοινοισμους 2006/42/EG, 2014/30/EU, 2011/65/EU
- (S) CE-17 - Konformitetsdeklaration. Vi förklarar på eget ansvar att denna produkt överensstämmer med följande normer eller normativa dokument: EN 62841-1, EN ISO 12100, EN ISO 13857, EN 349, EN 28662-1, EN 61000-6-3, EN 61000-6-2, EN 60529, EN 1037 enligt bestämmelserna i direktiverna 2006/42/EG, 2014/30/EU, 2011/65/EU
- (DK) CE-17 - Konformitetserklæring. Vi erklærer under almindeligt ansvar at dette produkt er i overensstemmelse med følgende normer eller normative dokumenter: EN 62841-1, EN ISO 12100, EN ISO 13857, EN 349, EN 28662-1, EN 61000-6-3, EN 61000-6-2, EN 60529, EN 1037 i henhold til bestemmelserne i direktiverne 2006/42/EØF, 2014/30/EU, 2011/65/EU
- (N) CE-17 - Konformitetserklæring. Vi erklærer på eget ansvarlighet at dette produkt er i overensstemmelse med følgende standarder eller standard-dokumenter: EN 62841-1, EN ISO 12100, EN ISO 13857, EN 349, EN 28662-1, EN 61000-6-3, EN 61000-6-2, EN 60529, EN 1037 i henhold til bestemmelserne i direktive ne 2006/42/EØF, 2014/30/EU, 2011/65/EU
- (FIN) CE-17 - Todistus standardinmukaissuudesta. Asiaa vastaavana todistamme täten, että tämä tuote on seuraavien standardien ja standardoimisasiakirjojen vaatimusten mukainen: EN 62841-1, EN ISO 12100, EN ISO 13857, EN 349, EN 28662-1, EN 61000-6-3, EN 61000-6-2, EN 60529, EN 1037 ja vastaa säädoksiä 2006/42/EG, 2014/30/EU, 2011/65/EU
- (SK) CE-17 - Prehlásenie o zhode. Prehlasujeme na vlastnú zodpovednosť, že tieto produkty sú v súlade s nasledovnými normami: EN 62841-1, EN ISO 12100, EN ISO 13857, EN 349, EN 28662-1, EN 61000-6-3, EN 61000-6-2, EN 60529, EN 1037 a v zhode so smernicami 2006/42/EG, 2014/30/EU, 2011/65/EU
- (PL) CE-17 - Zgodnosc z dyrektywami CE. Swiadomy odpowiedzialnosci oswiadczamy, ze niniejszy produkt jest zgodny z nastepujacymi normami lub dokumentacja normatywna: EN 62841-1, EN ISO 12100, EN ISO 13857, EN 349, EN 28662-1, EN 61000-6-3, EN 61000-6-2, EN 60529, EN 1037 zgodnie z postanowieniami wytycznych 2006/42/EG, 2014/30/EU, 2011/65/EU
- (CZ) CE-17 - Prohlášení o shode. Prohlasujeme na vlastní zodpovednost, ze tyto produkty splnuji následující normy nebo normativní listiny: EN 62841-1, EN ISO 12100, EN ISO 13857, EN 349, EN 28662-1, EN 61000-6-3, EN 61000-6-2, EN 60529, EN 1037; Ve shode se smernicami 2006/42/EG, 2014/30/EU, 2011/65/EU
- (SLO) CE-17 - Izjava o skladnosti. S tem potrjujemo splosno odgovornost, da je ta izdelek narejen v skladu z navedenimi normami in standardi: EN 62841-1, EN ISO 12100, EN ISO 13857, EN 349, EN 28662-1, EN 61000-6-3, EN 61000-6-2, EN 60529, EN 1037 ter določbami in smernicami 2006/42/EG, 2014/30/EU, 2011/65/EU
- (HR) CE-17 - Izjava o skladnosti. Pod punom odgovornošću izjavljujemo da je proizvod naveden u naslovu ovog dokumenta sukladan sa primijenjenim normama i normativnim dokumentima: EN 62841-1, EN ISO 12100, EN ISO 13857, EN 349, EN 28662-1, EN 61000-6-3, EN 61000-6-2, EN 60529, EN 1037 u skladu sa odredbama preporuka 2006/42/EG, 2014/30/EU, 2011/65/EU
- (H) CE-17 - Megfelelőeségi nyilatkozat. Kéziműkötetésű elektromos kéziszerszámok: Teljes felelősséggel kijelentjük, hogy ezek a termékek a következő szabványokkal és irányelvekkel összhangban vannak: EN 62841-1, EN ISO 12100, EN ISO 13857, EN 349, EN 28662-1, EN 61000-6-3, EN 61000-6-2, EN 60529, EN 1037; és megfelelnek a rendeltetés szerinti 2006/42/EG, 2014/30/EU, 2011/65/EU irányelveknek.
- (RO) CE-17 - Declarație de conformitate. Noi declarăm pe propria răspundere că acest produs este în conformitate cu următoarele norme și documente normative: EN 62841-1, EN ISO 12100, EN ISO 13857, EN 349, EN 28662-1, EN 61000-6-3, EN 61000-6-2, EN 60529, EN 1037; potrivit dispozițiilor directivelor 2006/42/EG, 2014/30/EU, 2011/65/EU

Remscheid, den 02.11.2017



Joh. - Christoph Schütz

Dipl.-Ing. Joh.-Christoph Schütz, CE-Beauftragter

(D) CE-'17 - Konformitätserklärung RED. Wir erklären in alleiniger Verantwortlichkeit, daß dieses Produkt mit den folgenden Normen oder normativen Dokumenten übereinstimmt: EN 60950-1, EN 301489-1, EN 301489-17, EN 300328 V2.1.1, EN 62479 gemäß den Bestimmungen der Richtlinien 2014/53/EU, 2011/65/EU

(GB) CE-'17 - Declaration of conformity RED. We declare under our sole responsibility that this product is in conformity with the following standards or normative documents: EN 60950-1, EN 301489-1, EN 301489-17, EN 300328 V2.1.1, EN 62479 in accordance with the regulations of directives 2014/53/EU, 2011/65/EU

(F) CE-'17 - Déclaration de conformité RED. Nous déclarons sous notre seule responsabilité que ce produit est en conformité avec les normes ou documents normatifs suivants: EN 60950-1, EN 301489-1, EN 301489-17, EN 300328 V2.1.1, EN 62479 conformément aux réglementations des directives 2014/53/EU, 2011/65/EU

(E) CE-'17 - Declaración de conformidad RED. Declaramos bajo nuestra sola responsabilidad que este producto está en conformidad con las normas o documentos normativos siguientes: EN 60950-1, EN 301489-1, EN 301489-17, EN 300328 V2.1.1, EN 62479 de acuerdo con las regulaciones de las directivas 2014/53/EU, 2011/65/EU

(I) CE-'17 - Dichiarazione di conformità RED. Dichiariamo sotto la nostra esclusiva responsabilità che questo prodotto è conforme alle seguenti norme e documenti normativi: EN 60950-1, EN 301489-1, EN 301489-17, EN 300328 V2.1.1, EN 62479 conformemente alle disposizioni delle direttive 2014/53/EU, 2011/65/EU

(P) CE-'17 - Declaração de conformidade RED. Declaramos sob nossa exclusiva responsabilidade que este produto cumpre as seguintes normas ou documentos normativos: EN 60950-1, EN 301489-1, EN 301489-17, EN 300328 V2.1.1, EN 62479 conforme as disposições das directivas 2014/53/EU, 2011/65/EU

(NL) CE-'17 - Konformiteitsverklaring RED. Wij verklaren en wij stellen ons er alleen voor verantwoordelijk dat dit produkt voldoet aan de volgende normen of normatieve documenten: EN 60950-1, EN 301489-1, EN 301489-17, EN 300328 V2.1.1, EN 62479 overeenkomstig de bepalingen van de richtlijnen 2014/53/EU, 2011/65/EU

(GR) CE-'17 - ΔΗΛΩΣΗ ΣΥΜΜΟΡΦΩΣΗΣ Μ RED. ϵ αναληψη συνολικης δηλωσιμε: οτι το πορον προιον συμφωρει με τα παρακατω ποοτυνα και με τα ηροτυνη ηου αναφερονται στα σχετικα εγγραφα ∞ EN 60950-1, EN 301489-1, EN 301489-17, EN 300328 V2.1.1, EN 62479 σύμφωνα με τοxα κοινοτυμοx 2014/53/EU, 2011/65/EU

(S) CE-'17 - Konformitetsdeklaration RED. Vi förklarar på eget ansvar att denna produkt överensstämmer med följande normer eller normativa dokument: EN 60950-1, EN 301489-1, EN 301489-17, EN 300328 V2.1.1, EN 62479 enligt bestämmelserna i direktiverna 2014/53/EU, 2011/65/EU

(DK) CE-'17 - Konformitetserklæring RED. Vi erklærer under almindeligt ansvar at dette produkt er i overensstemmelse med følgende normer eller normative dokumenter: EN 60950-1, EN 301489-1, EN 301489-17, EN 300328 V2.1.1, EN 62479 i henhold til bestemmelserne i direktivene 2014/53/EU, 2011/65/EU

(N) CE-'17 - Konformitetserklæring RED. Vi erklærer på eget ansvar at dette produkt er i overensstemmelse med følgende standarder eller standard-dokumenter: EN 60950-1, EN 301489-1, EN 301489-17, EN 300328 V2.1.1, EN 62479 i henhold til bestemmelsene i direktive ne 2014/53/EU, 2011/65/EU

(FIN) CE-'17 - Todistus standardin mukaisuudesta RED. Asiasta vastaavana todistamme läten, että tämä tuote on seuraavien standardien ja standardoimisasiakirjojen vaatimusten mukainen: EN 60950-1, EN 301489-1, EN 301489-17, EN 300328 V2.1.1, EN 62479 ja vastaa säädöksiä 2014/53/EU, 2011/65/EU

(SK) CE-'17 - Prehlásenie o zhode RED. Prehlasujeme na vlastnú zodpovednosť, že tieto produkty sú v súlade s nasledovnými normami: EN 60950-1, EN 301489-1, EN 301489-17, EN 300328 V2.1.1, EN 62479 a v zhode so smernicami 2014/53/EU, 2011/65/EU

(PL) CE-'17 - Zgodność z dyrektywami RED. Świadomi odpowiedzialności oświadczamy, że niniejszy produkt jest zgodny z następującymi normami lub dokumentacja normatywna: EN 60950-1, EN 301489-1, EN 301489-17, EN 300328 V2.1.1, EN 62479 zgodnie z postanowieniami wytycznych 2014/53/EU, 2011/65/EU

(CZ) CE-'17 - Prohlášení o shode RED. Prohlasujeme na vlastní zodpovednosť, že tyto produkty splňují následující normy nebo normativní listiny: EN 60950-1, EN 301489-1, EN 301489-17, EN 300328 V2.1.1, EN 62479 Ve shode se smernicami 2014/53/EU, 2011/65/EU

(SLO) CE-'17 - Izjava o skladnosti RED. S tem potrjujemo splošno odgovornost, da je ta izdelek narejen v skladu z navedenimi normami in standardi EN 60950-1, EN 301489-1, EN 301489-17, EN 300328 V2.1.1, EN 62479 ter določbami in smernicami 2014/53/EU, 2011/65/EU

(HR) CE-'17 - Izjava o skladnosti RED. Pod punom odgovornošću izjavljujemo da je proizvod naveden u naslovu ovog dokumenta skladan sa primijenjenim normama i normativnim dokumentima : EN 60950-1, EN 301489-1, EN 301489-17, EN 300328 V2.1.1, EN 62479 u skladu sa odredbama preporuka 2014/53/EU, 2011/65/EU

(H) CE-'17 - Megfelelősségi nyilatkozat RED. Kéziműködtetésű elektromos kéziszerszámok. Teljes felelősséggel kijelentjük, hogy ezek a termékek a következő szabványokkal és irányelvekkel összhangban vannak: EN 60950-1, EN 301489-1, EN 301489-17, EN 300328 V2.1.1, EN 62479 és megfelelnek a rendeltetés 2014/53/EU, 2011/65/EU irányelveknek.

(RO) CE-'17 - Declarație de conformitate RED. Noi declarăm pe propria răspundere că acest produs este în conformitate cu următoarele norme și documente normative: EN 60950-1, EN 301489-1, EN 301489-17, EN 300328 V2.1.1, EN 62479 potrivit dispozițiilor directivelor 2014/53/EU, 2011/65/EU

Remscheid, den 01.11.2017

Dipl.-Ing. Joh.-Christoph Schütz, CE-Beauftragter