

Cables, Wires & Accessories

E-MOBILITY

Ed. 1.1 // GB

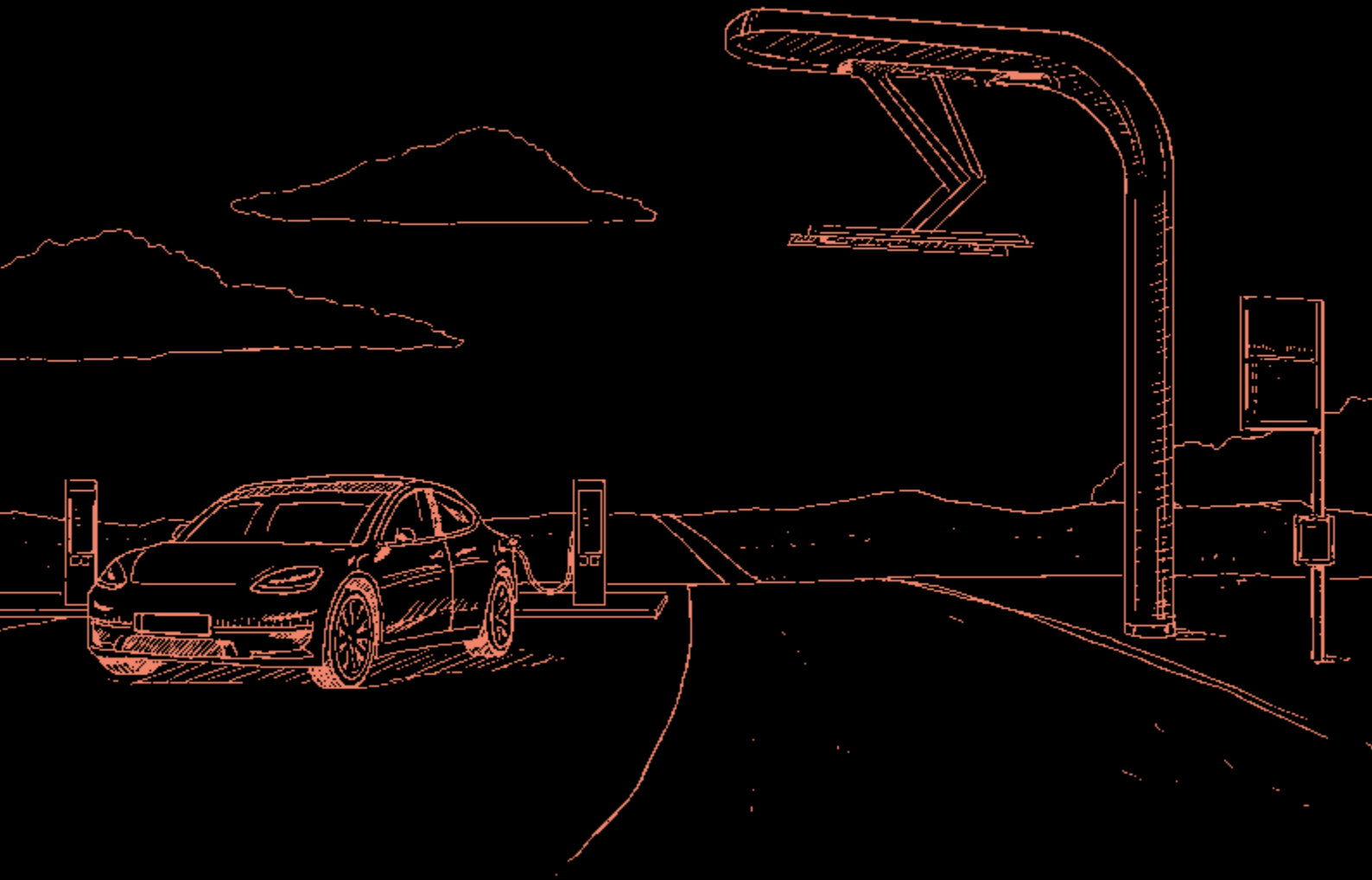

**(Channeling
POWER)** 

Icons

Approvals / Standards



UL



CSA



HAR



VDE REG Number



SPAIN



EAC



CCC



CE



DNV-GL



IPA



DESINA

Properties / Applications



Halogen-Free



UV Radiation



Robust



Drag Chain



Torsion



Wind-Offshore



Meter Marking



In Feet

Explanation of the icons used in the brochure:

The icons are intended to provide a general overview of material properties and certifications. For details, please refer to the information in the data sheets.

Contents

Content	Page	Content	Page
Icons	02	HELUTHERM® 145	48
Contents	03	HELUTHERM® 145 UL/CSA 600V	50
HELUKABEL – Channeling POWER	04	HELUPOWER® THERMFLEX® 145-Single	53
HELUKABEL – Channeling Innovation	06	HELUPOWER® THERMFLEX® 145	54
HELUKABEL – Channeling Logistics	08	HELUPOWER® THERMFLEX® 145-C	55
Overview Applications	10	HELUWIND® WK POWERLINE ALU 0,6/1 kV	56
Charging Establishments & Charging Connections	12	Selection Table WK Powerline ALU	57
HELUPOWER® CHARGE-750-AC	14	Selection List Earth & Power Distribution Cables	59
HELUPOWER® CHARGE-1200-DC	15	LAN-Cable Outdoor Use	60
HELUPOWER® CHARGE-1000-AC-UL	16	LAN-Cable Direct Burial	61
HELUPOWER® CHARGE-1000-DC-UL	17	BUS-Cable Profibus L2	62
Charging Cable Configurator	18	BUS-Cable CAN Bus	63
Reeling Cables	20	Wallbox	64
Charging Technology for Buses & Trucks	22	Patch Cable Industrial Ethernet 200IND PUR	65
Hybrid Cables	26	Patch Cable Industrial Ethernet EXTRAFLEX	66
Wireless Charging	27	HELUKABEL® USB BUS S 2.0	67
Single 600-J / Single 600-O	32	Pre-Assembled Fibre Optic Cables	69
Single 600-CY-J / Single 600-CY-O	33	HELUTOP® HT	70
Single 602-RC-J / Single 602-RC-O	34	HELUTOP® HT-MS	72
Single 602-RC-CY-J / Single 602-RC-CY-O	35	HELUTOP® MS-EP4	74
HELUPOWER® H07RN-F LSOH	36	SD-XXL	75
HELUWIND® WK DLO, WK DLO-Torsion	38	HELUcond PP-MOD-FPPS-O	76
NFPA 79 Edition 2012	39	HELUcond PP-MOD-2PPS-O	77
HELUPOWER® 1100-RZ1-K LSOH GREEN	40	Glossary	78
NSGAFÖU 1,8/3 kV	42	Request Spiral Cables	80
JZ-600 / OZ-600	43	Request Reeling Cables	81
JZ-600-Y-CY / OZ-600-Y-CY	46	Notes	82
		Tips & Contact	83

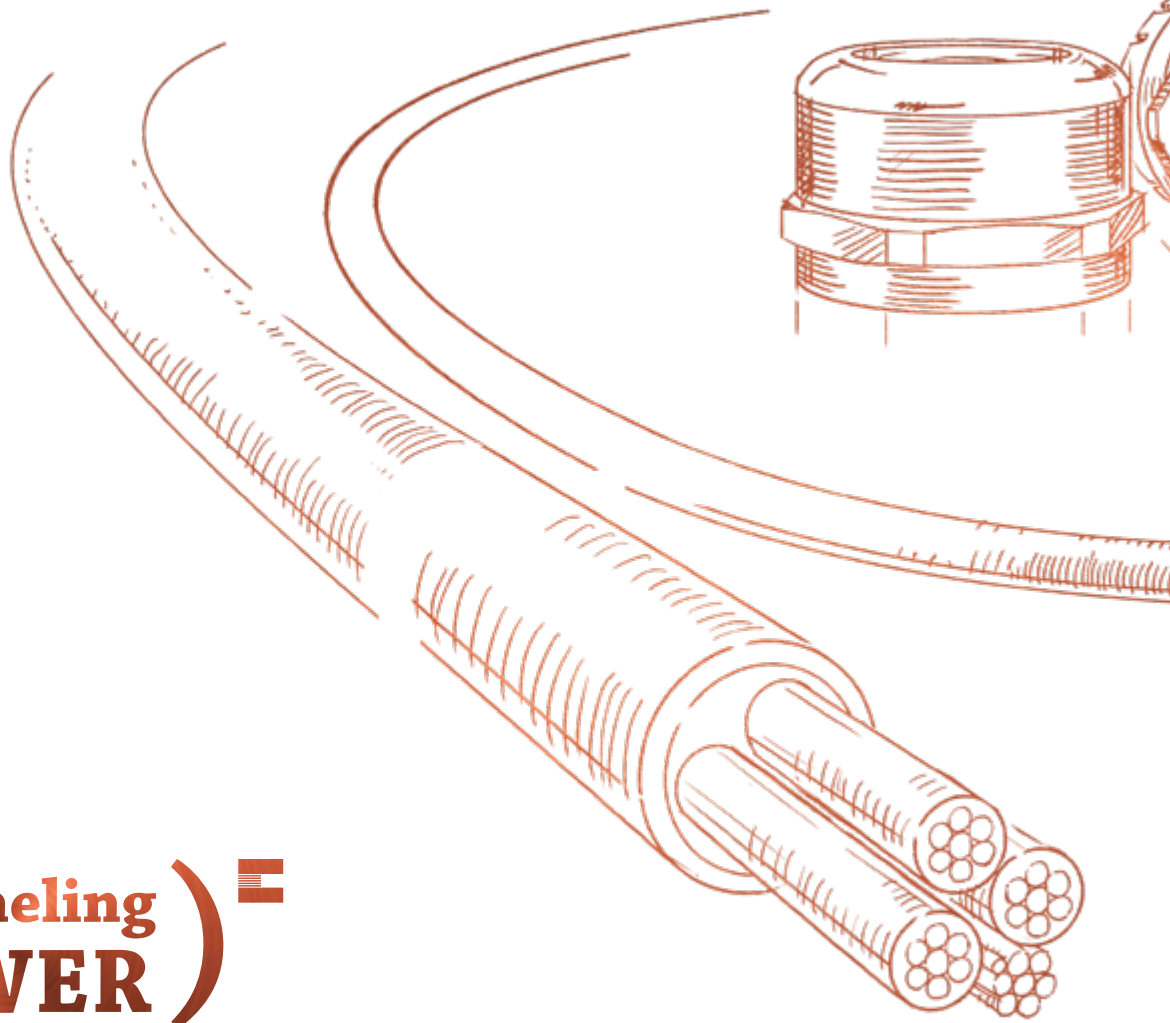

(Channeling POWER)

Cables are the vital supply lines of complex machines, plants, and systems. Whether operating under extreme mechanical stress, in the middle of the Arctic Ocean, in the scorching heat, or in the vastness of space – such conditions demonstrate what top-of-the-line cables can achieve.

We at HELUKABEL have made it our mission to bring energy and communication to our customers' destinations reliably and consistently at all times, and to make the

impossible, possible! "Channeling Power" succinctly summarizes this mission and is our commitment to customers.

Over 1,700 employees located at 55 sites across 36 countries work towards this common goal. We see it as our challenge to find the right cable solution for you every day, giving you the time to concentrate on more important things than cables and wires. This is where our products truly create value for you and your application.

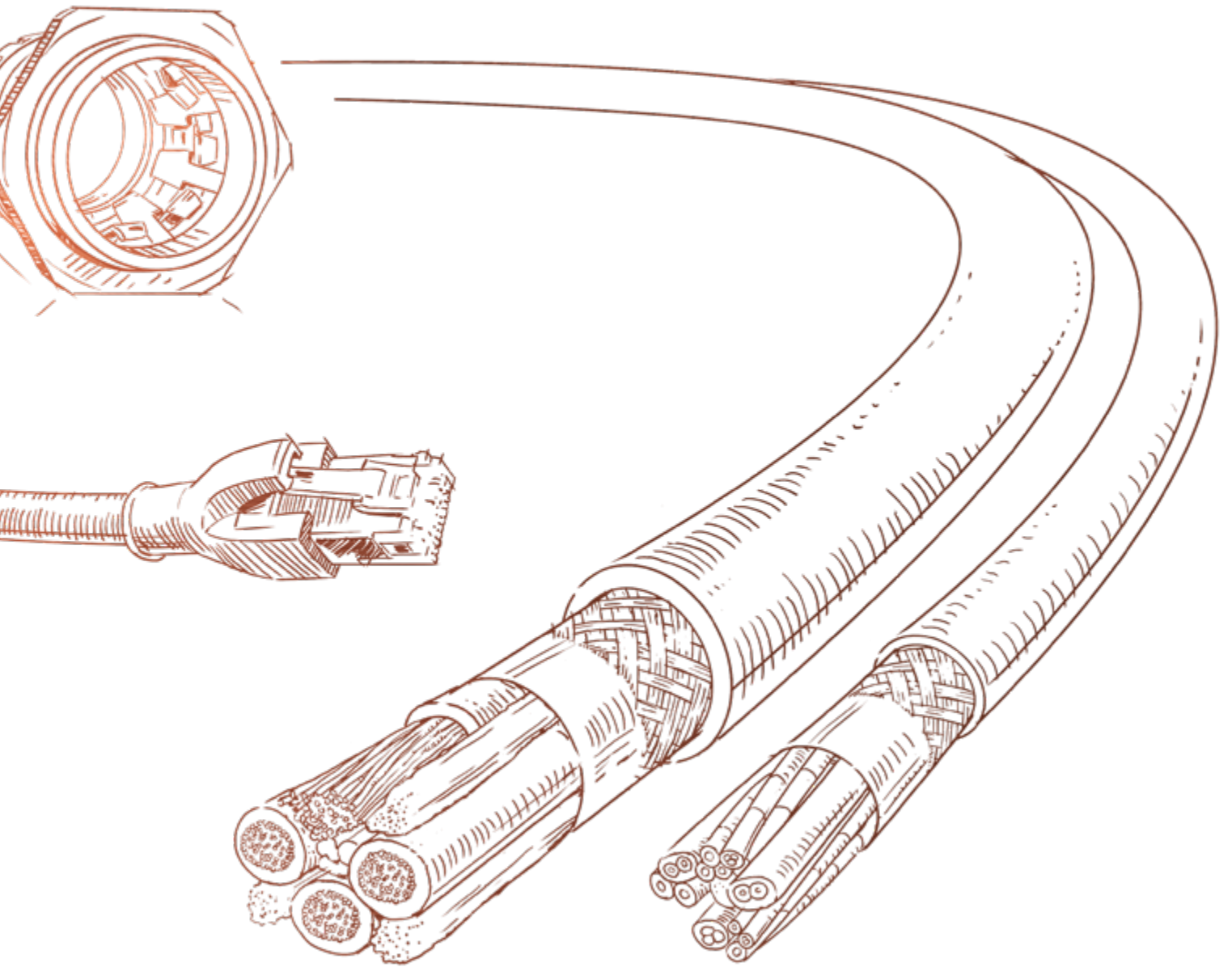

Channeling **INNOVATION**



A cable is only as good as the minds that ask the right questions before it's made. We have a lot of bright minds at HELUKABEL who spend every day searching for intelligent answers. This is important because the challenges faced by modern cables and wires are multifaceted: for example, moving applications with more than ten million cycles, exposure to extreme mechanical and chemical loads, tricky bending radii and space-saving hybrid solutions. For each situation, HELUKABEL has answers

to help you. To ensure there are no issues during use, all newly developed products undergo rigorous testing at our R&D centre in Windsbach, near Nuremberg. Here we bend, pull, grind and ignite the cable for all it's worth. Our special aging ovens are time machines that simulate a cable's life cycle and far beyond. Our cables are tested to comply with national and international standards, and all results are signed and sealed.

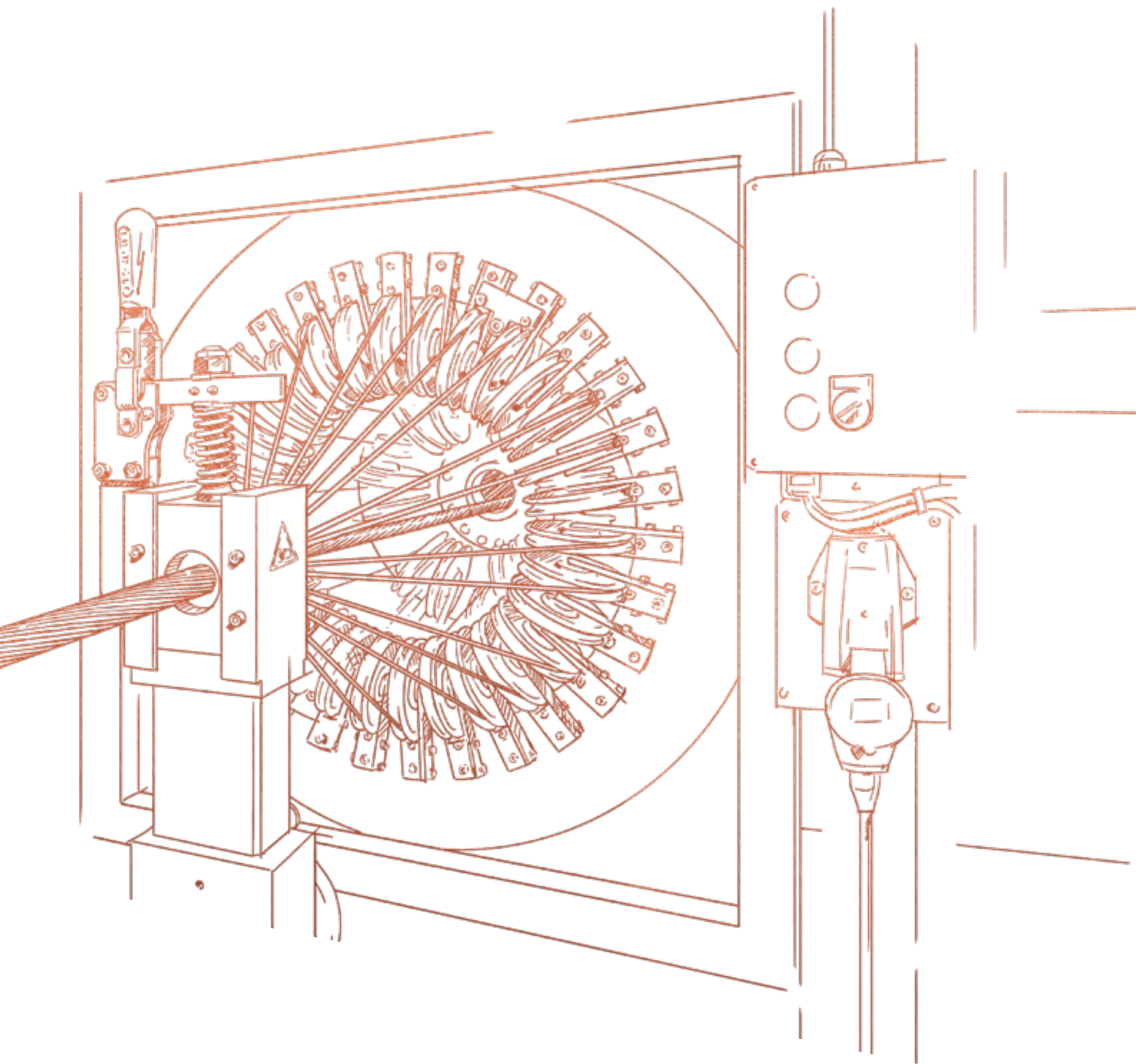

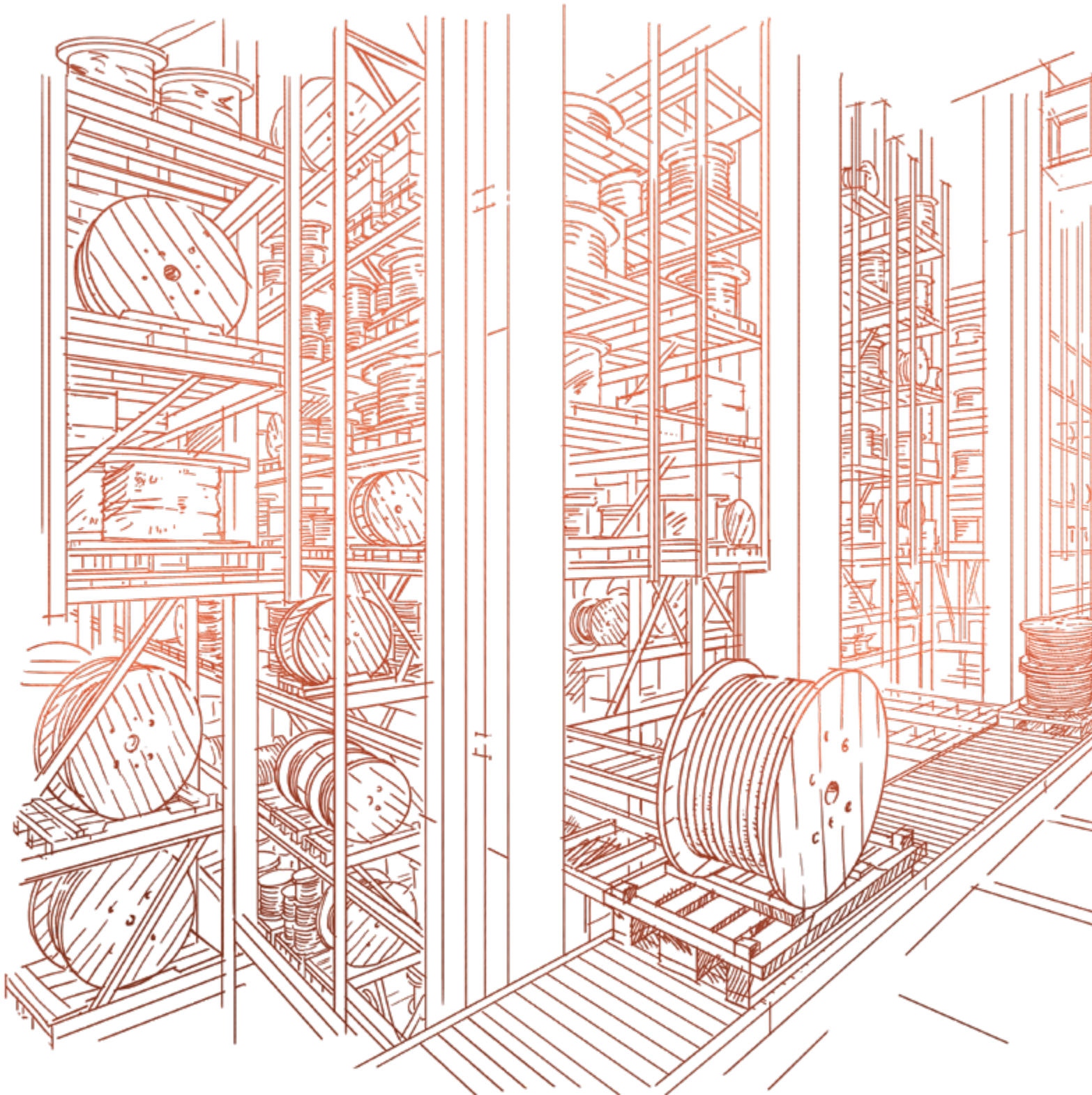

Channeling (LOGISTICS)

Where there's no cable there's no data nor electricity. When everything's going according to plan, cables are of little interest to anyone; but inevitably the day comes when a machine starts malfunctioning or a missing cable is holding up the completion of a project task. Whatever the situation in which problems occur, the time can be tense and critical for everyone involved.

At HELUKABEL, we try to remove the stress you're experiencing as quickly as possible. To this end, we built the biggest distribution centre for cable products in Europe.

With over 40,000 products stored in a fully automated, high-bay warehouse, we're ready to act upon your needs quickly and ship you the right cable at a moment's notice. Our "known shipper" status with the Federal Office of Civil Aviation means that your goods are checked in and pass security control directly at our warehouse, which speeds up the shipment process. On top of this, we have 32 additional warehouses on 5 continents so you can order your cables in Spanish, Russian, Chinese or in 23 other languages.

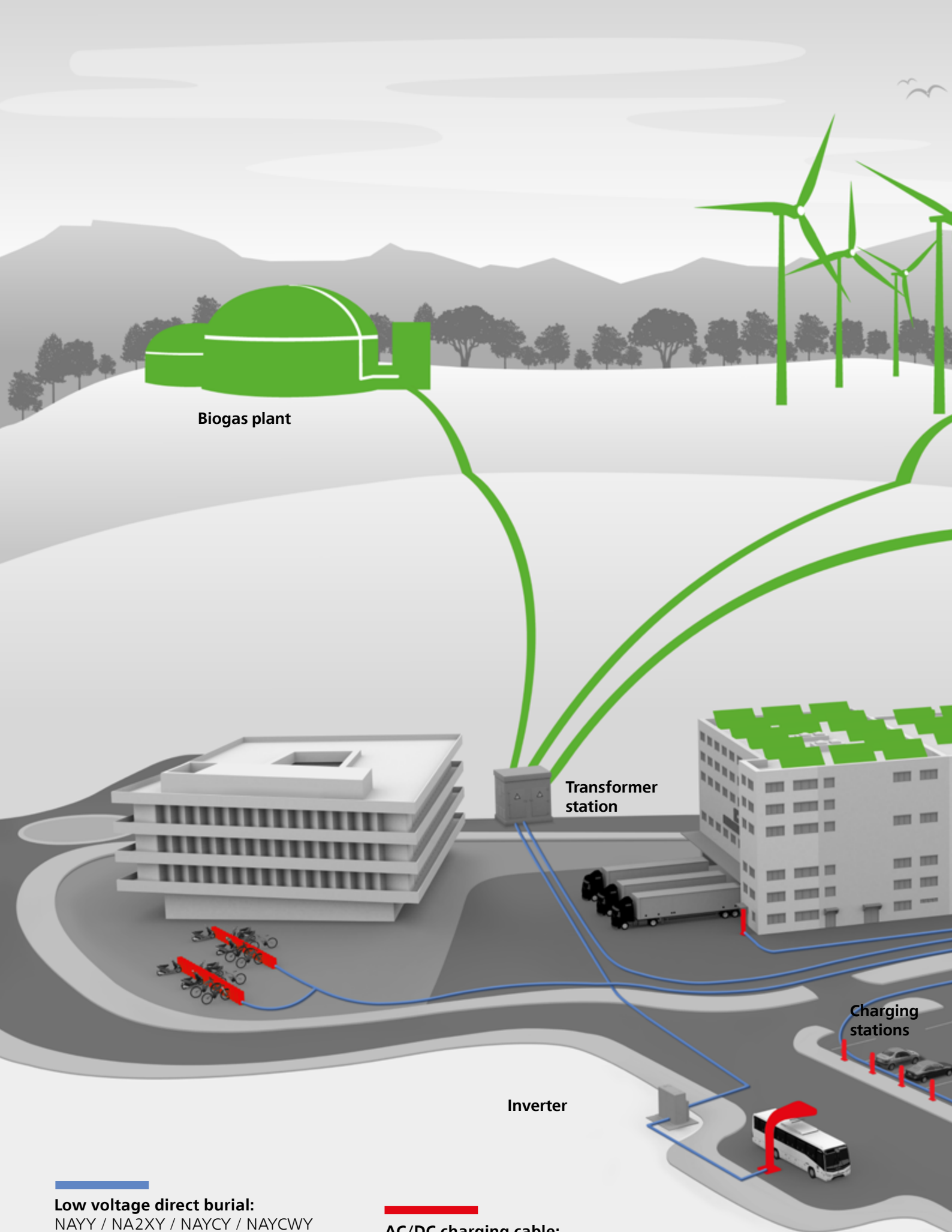

Biogas plant

Transformer station

Inverter

Charging stations

Low voltage direct burial:

NAYY / NA2XY / NAYCY / NAYCWY

Medium voltage direct burial:

NA2XS_Y / NA2XS_{2Y} / NA2XS(F)2Y

AC/DC charging cable:

HELUPOWER® CHARGE 750 AC

HELUPOWER® CHARGE 1200 DC

Optional: liquid-cooled DC cables

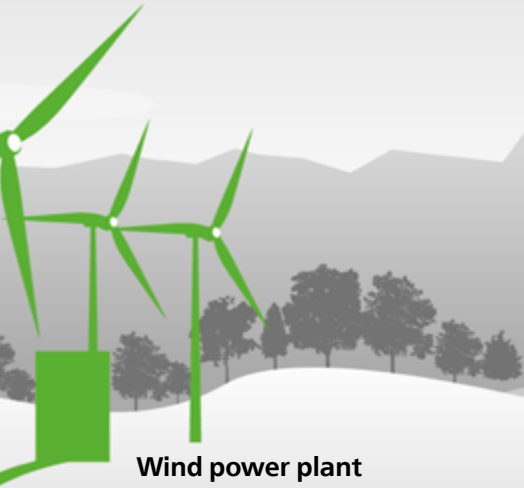

Wind power plant

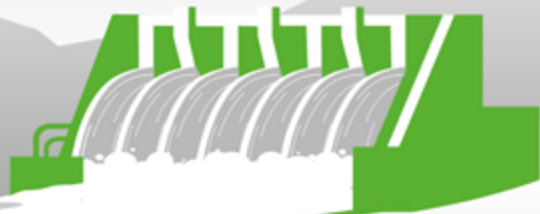

Hydroelectric power plant



Photovoltaic

Switchgear station with ESS

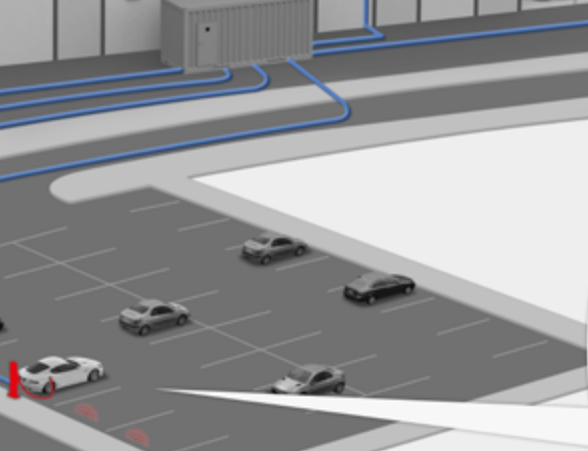

Inductive parking lot



Charging Modes

Mode 1

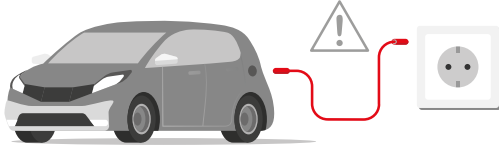

Mode 2

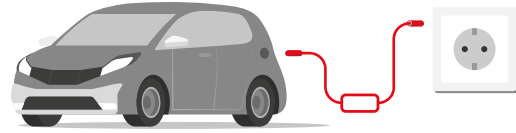

Mode 3

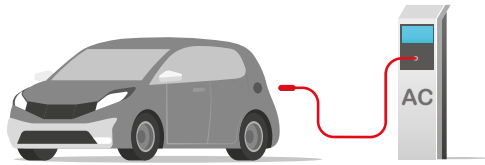



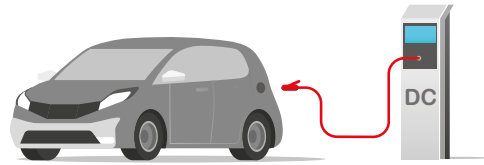









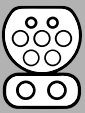

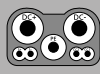

Mode 4



Charging Connections

	Schuko/US	CEE blue	CCE red	Type 1	Type 2	GB/T AC
AC						
Current type	1 Phase	1 Phase	3 Phase	1 Phase	3 Phase	3 Phase
Voltage level (V)	230	230	230 (400)	230	230 (400)	230 (400)
Amps (A) max.	10	16	16	32	63	63
Max. power (kW)	2	3,7	11	7,4	44	44
Charging cable	Mode 2	Mode 2	Mode 2	Mode 3	Mode 3	Mode 3
Region	EU, USA	EU	EU	USA, Japan	EU	China

Charging mode	Communication	Plugs	Capacity	Current type	HELUKABEL
Mode 1	None	No longer in use	Single-phase: max. 16 A, 3,7 kW	AC	No longer in use
			Three-phase: max. 16 A, 11 kW		
Mode 2	Between communication module and vehicle	Type 2 -Schuko	Single-phase: max. 16 A, 3,7 kW	AC	HELUPOWER® Charge 750 AC
			Three-phase: max. 32 A, 22 kW		
Mode 3	Between vehicle and charging station	Type 2	Single-phase: max. 16 A, 3,7 kW	AC	HELUPOWER® Charge 750 AC
			Three-phase: max. 63 A, 43.6 kW		
Mode 4	Between vehicle and charging station	CCS or CHAdeMO	50 kW up to 350 kW, to 500A (200V - 900V)	DC	HELUPOWER® Charge 1200 DC

	Tesla	Tesla	CCS 2	CCS 1	GB/T DC	GB/T Chaoji	CHAdeMO
DC							
Current type	DC	DC	DC		DC	DC	DC
Voltage level (V)	410	410	1000		950	1500	1000
Amps (A) max.	330	330	200-(500)		250	600	400
Max. power (kW)	135	135	350		238	900	500
Charging cable	Mode 4	Mode 5	Mode 4		Mode 4	Mode 4	Mode 4
Region	EU	USA, Japan	CCS2 EU	CCS1 USA	China	China	USA, Japan, EU
		 					  

HELUPOWER® CHARGE-750-AC

flexible, flame retardant



TECHNICAL DATA

E-Mobility charging cable according to DIN VDE 0285-620 / DIN EN 50620 / GB/T 33594-2017

Temperature range	flexible -40°C bis +90°C fixed -40°C bis +90°C
Permissible operating temperature of the conductor	+90°C
Nominal voltage	U ₀ /U 450/750 V AC
Test voltage	signal cores: 2000 V DC power cores: 2500 V AC complete cable: 3500 V AC
Minimum bending radius	flexible 7,5 x Kabel-Ø fixed 4 x Kabel-Ø

■ CABLE STRUCTURE

- power and signal cores: bare copper conductor acc. to DIN VDE 0295 cl. 5, fine wire, IEC 60228 Kl. 5
- core insulation: halogen-free polymer type EVI-2 acc. to DIN EN 50620
- core identification: signal cores acc. to DIN VDE 0285-620 / DIN EN 50620 and DIN VDE 0293-334 / DIN EN 50334
power supply cores: colour coding acc. to DIN VDE 0293-308 and HD 308 S2
- outer sheath: halogen-free polymer type EVM-1 acc. to DIN EN 50620
- outer sheath colour: black or red (RAL 3020)
- with meter marking

■ PROPERTIES

- resistant to: oil, UV radiation
- halogen-free
- flame retardant

■ TESTS

- oil resistant acc. to DIN VDE 0207-363-10-2 / DIN EN 50363-10-2
- flame retardant acc. to DIN VDE 0482-332-1 / DIN EN 60332-1 / IEC 60332-1
- halogen-free acc. to DIN VDE 0285-620 / DIN EN 50620
- UV-resistant acc. to DIN VDE 0285-620 / DIN EN 50620

■ APPLICATION

E-Mobility charging cable for multiple use scenarios. It can be used for charging electronic vehicles at public charge stations like parking areas, near highways or in garages as well as at domestic sockets. The UV and oil resistance ensure a reliable charging process indoors and outdoors. Due to its TPE-U outer sheath it even withstands harsh handling on concrete.

■ NOTES

- other constructions or outer sheath colours available on request
- UL 62 charging cable available on request
- can also be delivered for alternating current as HELUPOWER® CHARGE 1200 DC

outer sheath: black

Part no.	No. cores x cross-sec. mm ²	Outer Ø app. mm	Copper weight kg/km	Weight app. kg / km
17001062	3 G 1.5 + 1 x 0.5	9.5	48.0	115
17001063	3 G 1.5 + 2 x 0.5	9.5	53.0	125
17001064	3 G 2.5 + 1 x 0.5	10.0	77.0	153
17001065	3 G 2.5 + 2 x 0.5	10.0	82.0	161
17001066	5 G 2.5 + 1 x 0.5	12.8	125.0	238
17001067	5 G 2.5 + 2 x 0.5	12.8	130.0	245
17001068	5 G 2.5 + 4 x 0.5	13.4	140.0	263
17001069	3 G 6 + 1 x 0.5	12.8	178.0	293
17001070	3 G 6 + 2 x 0.5	12.8	183.0	300
17001071	5 G 6 + 1 x 0.5	16.0	293.0	455
17001072	5 G 6 + 2 x 0.5	16.0	298.0	461
17001073	5 G 16 + 1 x 1	22.7	778.0	1100

outer sheath: red

Part no.	No. cores x cross-sec. mm ²	Outer Ø app. mm	Copper weight kg/km	Weight app. kg / km
17001074	3 G 1.5 + 1 x 0.5	9.5	48.0	115
17001075	3 G 1.5 + 2 x 0.5	9.5	53.0	125
17001076	3 G 2.5 + 1 x 0.5	10.0	77.0	153
17001077	3 G 2.5 + 2 x 0.5	10.0	82.0	161
17001078	5 G 2.5 + 1 x 0.5	12.8	125.0	238
17001079	5 G 2.5 + 2 x 0.5	12.8	130.0	245
17001080	5 G 2.5 + 4 x 0.5	13.4	140.0	263
17001081	3 G 6 + 1 x 0.5	12.8	178.0	293
17001082	3 G 6 + 2 x 0.5	12.8	183.0	300
17001083	5 G 6 + 1 x 0.5	16.0	293.0	455
17001084	5 G 6 + 2 x 0.5	16.0	298.0	461
17001085	5 G 16 + 1 x 1	22.7	778.0	1100

HELUPOWER® CHARGE-1200-DC

flexible, flame retardant



TECHNICAL DATA

E-Mobility charging cable with VDE-REG No.

Temperature range	flexible -40°C bis +90°C fixed -40°C bis +90°C
Permissible operating temperature of the conductor	+90°C
Nominal voltage	U ₀ /U 600/1200 V DC
Test voltage	signal cores: 2000 V DC power cores: 2500 V AC complete cable: 3500 V AC
Minimum bending radius	flexible 7,5 x Kabel-Ø fixed 4 x Kabel-Ø

■ CABLE STRUCTURE

- bare copper-conductor acc. to DIN VDE 0295 cl. 6, finest wire, BS 6360 cl. 6, IEC 60228 cl. 6
- core insulation: halogen-free polymer type EVI-2 acc. to DIN 50620
- core identification: signal cores acc. to DIN VDE 0285-620 / DIN EN 50620 and DIN VDE 0293-334 / DIN EN 50334
power supply cores: BK/RD/GNYE
- outer sheath: halogen-free polymer type EVM-1 acc. to DIN EN 50620
- outer sheath colour: black or red (RAL 3020)
- with meter marking

outer sheath: black

Part no.	No. cores x cross-sec. mm ²	Outer Ø app. mm	Copper weight kg/km	Weight app. kg / km
17001086	3 G 16 + 3 x 2 x 0.75	19.2	525.0	780
17001087	2 x 35 + 1 G 25 + 3 x 2 x 0.75	26.0	995.0	1300
17001088	2 x 50 + 1 G 25 + 6 x 0.75	28.6	1295.0	1650
17001089	2 x 70 + 1 G 35 + 6 x 0.75	32.5	1795.0	2300

■ PROPERTIES

- resistant to: oil, UV radiation
- halogen-free
- flame retardant

■ TESTS

- oil resistant acc. to DIN VDE 0207-363-10-2 / DIN EN 50363-10-2
- flame retardant acc. to DIN VDE 0482-332-1 / DIN EN 60332-1 / IEC 60332-1
- halogen-free acc. to DIN VDE 0285-620 / DIN EN 50620
- UV-resistant acc. to DIN VDE 0285-620 / DIN EN 50620

■ APPLICATION

E-Mobility charging cable for multiple use scenarios. It can be used for charging electronic vehicles at public charge stations like parking areas, near highways or in garages as well as at domestic sockets. The UV and oil resistance ensure a reliable charging process indoors and outdoors. Due to its TPE-U outer sheath, it even withstands harsh handling on concrete. The high voltage with 1200 V direct current (DC) enables quick charging and therefore reduces the charging time significantly.

■ NOTES

- other constructions or outer sheath colours available on request
- UL 62 charging cable available on request
- can also be delivered for alternating current as HELUPOWER® CHARGE 750 AC
- according to DIN VDE 0285-620 / DIN EN 50620 / GB/T 33594-2017

outer sheath: red

Part no.	No. cores x cross-sec. mm ²	Outer Ø app. mm	Copper weight kg/km	Weight app. kg / km
17001090	3 G 16 + 3 x 2 x 0.75	19.2	525.0	780
17001091	2 x 35 + 1 G 25 + 3 x 2 x 0.75	26.0	995.0	1300
17001092	2 x 50 + 1 G 25 + 6 x 0.75	28.6	1295.0	1650
17001093	2 x 70 + 1 G 35 + 6 x 0.75	32.5	1795.0	2300

HELUPOWER® CHARGE-1000-AC-UL

flexible, flame retardant



TECHNICAL DATA

E-Mobility charging cable according to UL 62

Temperature range	flexible -40°C bis +90°C fixed -40°C bis +90°C
Permissible operating temperature of the conductor	+90°C
Nominal voltage	EVJE U 300 V AC EVE U 1000 V AC
Test voltage	2000 V AC
Minimum bending radius	flexible 7,5 x Kabel-Ø fixed 4 x Kabel-Ø

■ CABLE STRUCTURE

- power and signal cores: bare copper conductor, fine wire acc. to UL 62
- core insulation: TPE-O
- core identification: coloured cores acc. to UL 62
- cores stranded in layers with optimal lay-length
- outer sheath: TPU
- outer sheath colour: black or red (RAL 3020)

■ PROPERTIES

- resistant to: oil, UV radiation
- flame retardant

■ TESTS

- flame retardant: vertical flame test FT1 acc. to UL 1581
- oil resistant acc. to UL 62
- weather resistant acc. to UL 62

■ APPLICATION

E-Mobility charging cable for multiple use scenarios. It can be used for charging electronic vehicles at public charge stations like parking areas, near highways or in garages as well as at domestic sockets. The UV and oil resistance ensure a reliable charging process indoors and outdoors. Due to its TPU outer sheath it even withstands harsh handling on concrete.

■ NOTES

- other constructions or outer sheath colours available on request
- can also be delivered for direct current as HELUPOWER® CHARGE-1000-DC-UL

outer sheath: black

Part no.	No. cores x cross-sec. mm ²	Outer Ø app. mm	Copper weight kg/km	Weight app. kg / km
17001265	3 x AWG 14 (2.08 mm ²) + 1 x AWG 20 (0.52 mm ²)	10.5	72.0	130
17001266	3 x AWG 14 (2.08 mm ²) + 1 x AWG 18 (0.82 mm ²)	10.7	75.0	140
17001267	3 x AWG 14 (2.08 mm ²) + 2 x AWG 18 (0.82 mm ²)	11.8	84.0	175
17001268	3 x AWG 12 (3.31 mm ²) + 1 x AWG 18 (0.82 mm ²)	15.2	111.0	310
17001269	3 x AWG 10 (5.26 mm ²) + 1 x AWG 20 (0.52 mm ²)	15.7	171.0	375
17001270	3 x AWG 10 (5.26 mm ²) + 1 x AWG 18 (0.82 mm ²)	16.0	174.0	380
17001271	3 x AWG 10 (5.26 mm ²) + 2 x AWG 20 (0.52 mm ²)	16.0	177.0	385
17001272	5 x AWG 10 (5.26 mm ²) + 1 x AWG 20 (0.52 mm ²)	19.8	281.0	590

outer sheath: red

Part no.	No. cores x cross-sec. mm ²	Outer Ø app. mm	Copper weight kg/km	Weight app. kg / km
17001273	3 x AWG 14 (2.08 mm ²) + 1 x AWG 20 (0.52 mm ²)	10.5	72.0	130
17001274	3 x AWG 14 (2.08 mm ²) + 1 x AWG 18 (0.82 mm ²)	10.7	75.0	140
17001275	3 x AWG 14 (2.08 mm ²) + 2 x AWG 18 (0.82 mm ²)	11.8	84.0	175
17001276	3 x AWG 12 (3.31 mm ²) + 1 x AWG 18 (0.82 mm ²)	15.2	111.0	310
17001277	3 x AWG 10 (5.26 mm ²) + 1 x AWG 20 (0.52 mm ²)	15.7	171.0	375
17001278	3 x AWG 10 (5.26 mm ²) + 1 x AWG 18 (0.82 mm ²)	16.0	174.0	380
17001279	3 x AWG 10 (5.26 mm ²) + 2 x AWG 20 (0.52 mm ²)	16.0	177.0	385
17001280	5 x AWG 10 (5.26 mm ²) + 1 x AWG 20 (0.52 mm ²)	19.8	281.0	590

HELUPOWER® CHARGE-1000-DC-UL

flexible, flame retardant



TECHNICAL DATA

E-Mobility charging cable according to UL 62

Temperature range flexible -40°C bis +90°C
fixed -40°C bis +90°C

Permissible operating temperature of the conductor
+90°C

Nominal voltage U 1000 V DC

Test voltage 2000 V DC

Minimum bending radius flexible 7,5 x Kabel-Ø
fixed 4 x Kabel-Ø

■ CABLE STRUCTURE

- power and signal cores: bare copper conductor, fine wire acc. to UL 62
- core insulation: TPE-O
- core identification: coloured cores acc. to UL 62
- cores stranded in layers with optimal lay-length
- outer sheath: TPU
- outer sheath colour: black or red (RAL 3020)

■ PROPERTIES

- resistant to: oil, UV radiation
- flame retardant

■ TESTS

- flame retardant: vertical flame test FT1 acc. to UL 1581
- oil resistant acc. to UL 62
- weather resistant acc. to UL 62

■ APPLICATION

E-Mobility charging cable for multiple use scenarios. It can be used for charging electronic vehicles at public charge stations like parking areas, near highways or in garages as well as at domestic sockets. The UV and oil resistance ensure a reliable charging process indoors and outdoors. Due to its TPU outer sheath it even withstands harsh handling on concrete.

■ NOTES

- other constructions or outer sheath colours available on request
- can also be delivered for alternating current as HELUPOWER® CHARGE-1000-AC-UL

outer sheath: black

Part no.	No. cores x cross-sec. mm ²	Outer Ø app. mm	Copper weight kg/km	Weight app. kg / km
17001533	3 x AWG 6 (13.3 mm ²) + 3 x 2 x AWG 18 (0.82 mm ²)	18.6	479.0	990
17001534	2 x AWG 2 (33.6 mm ²) + 1 x AWG 4 (21.2 mm ²) + 3 x 2 x AWG 18 (0.82 mm ²)	25.1	950.0	1570
17001535	2 x AWG 1 (42.4 mm ²) + 1 x AWG 3 (26.7 mm ²) + 1 x 6 x AWG 18 (0.82 mm ²)	28.2	1234.0	2040
17001536	2 x AWG 2/0 (67.4 mm ²) + 1 x AWG 3 (26.7 mm ²) + 1 x 6 x AWG 18 (0.82 mm ²)	39.2	1674.0	2700



outer sheath: red

Part no.	No. cores x cross-sec. mm ²	Outer Ø app. mm	Copper weight kg/km	Weight app. kg / km
17001537	3 x AWG 6 (13.3 mm ²) + 3 x 2 x AWG 18 (0.82 mm ²)	18.6	479.0	990
17001538	2 x AWG 2 (33.6 mm ²) + 1 x AWG 4 (21.2 mm ²) + 3 x 2 x AWG 18 (0.82 mm ²)	25.1	950.0	1570
17001539	2 x AWG 1 (42.4 mm ²) + 1 x AWG 3 (26.7 mm ²) + 1 x 6 x AWG 18 (0.82 mm ²)	28.2	1234.0	2040
17001540	2 x AWG 2/0 (67.4 mm ²) + 1 x AWG 3 (26.7 mm ²) + 1 x 6 x AWG 18 (0.82 mm ²)	39.2	1674.0	2700

Charging Cable Configurator



HELUPOWER® CHARGE AC / DC

Guide to identifying desired combination options AC (Mode 2/3)

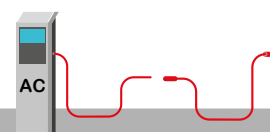
AC (Mode 2/3)				Page B Infrastructure (plug)						
Charging cable / mm ²	Current carrying capacity/A	Number of phases	Type Charging cable assemblies	Number pieces	Sheath colour (red/black = standard)	Length /m	GB/T	Typ2	Spiral (yes = X)	Open end
Side A Vehicle (socket)	3G2,5+1x0,5 (metric)	16	1	Type 1 USA 						
	3x14AWG+1x20AWG	16	1							
	3G6+1x0,5 (metric)	32	1							
	3x10AWG+1x18AWG	32	1							
	3G2,5+1x0,5	16	1	Type 2 EU 						
	3G6+1x0,5	32	1							
	5G2,5+1x0,5	16	3							
	5G6+1x0,5	32	3							
	5G16+1x0.5	63	3							
	3G2,5+1x0,5	16	1	GB/T China 						
	3G6+1x0,5	32	1							
	5G2,5+1x0,5	16	3							
5G6+1x0,5	32	3								



Guide to identifying desired combination options DC (Mode 4)

DC (Mode 4)				Page B Infrastructure (plug)		
Charging cable / mm ²	Current carrying capacity/A	Number of phases	Type Charging cable assemblies	Number pieces	Sheath colour (red/black = standard)	Length /m
Side A Vehicle (socket)	3xAWG 6+3x2xAWG 18	60	DC	CCS1 USA 		
	2xAWG 2+1xAWG 4+3x2xAWG 18	100				
	2xAWG 1+1xAWG 3+1x6 AWG 18	125				
	2xAWG 2/0+1xAWG 3+1x6xAWG 8	200				
	2x16+1G16+3x2x0.75	60		CCS2 EU 		
	2x35+1G25+3x2x0.75	100				
	2x50+1G25+3x2x0.75	125				
	2x70+1G35+6x0.75	200				
	3x16+2x4+(2x0,75)+10x0,75	80		GB/T China 		
	2x35+1x25+2x4+(2x0,75)+10x0,75	125				
	2x50+1x25+2x4+(2x0,75)+10x0,75	180				
	2x70+1x25+2x4+(2x0,75)+10x0,75	250				



Enquiry form spiral cable
Charging cables HELUPOWER® Charge 750 AC
Find on page 80

Reeling Cables

CHARGING STATIONS FOR ELECTRIC CARS

Robust, flexible and abrasion resistant: Reeling cables must function reliably, even when exposed to extreme mechanical stresses. This is precisely why we test our cables beyond their limits under real

conditions. With this, we can be sure that our reeling cables, designed to sustain a very high number of cycles, keep their promise.

Charging station

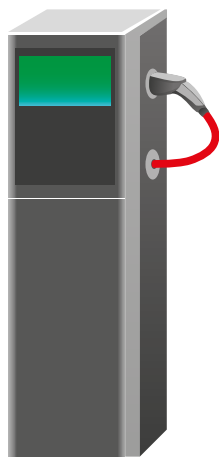

Charging station, open

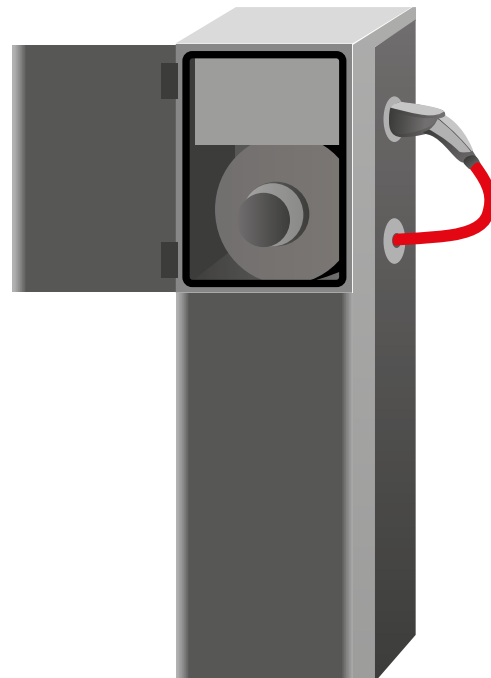

Drum with cable in the charging station

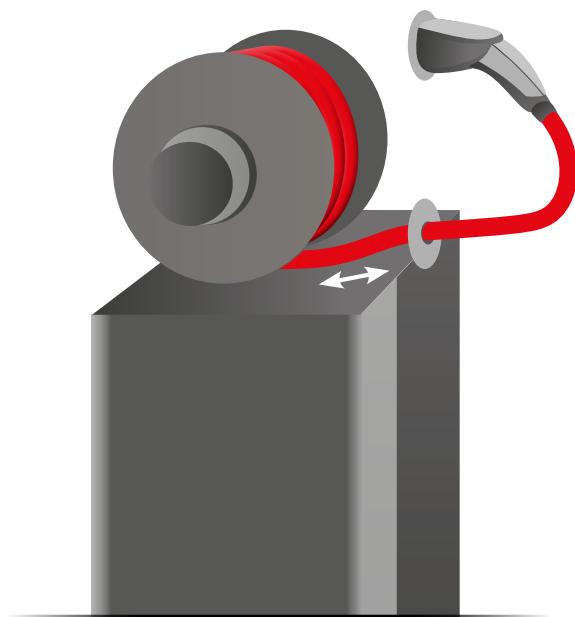

Reeling cables are mainly used in charging stations for electric vehicles. They are designed to be unwound and rewound by means of a spring cable reel. And this is how it works: Users pull the cable up to their vehicle, plug it in and pull it out again when the desired charge level is reached. The spring drum guides the cable and winds it neatly on and off the reel again so that the current can easily flow into the next e-vehicle.

DEPOT CHARGING SYSTEM

While charging electric cars involves comparatively low charging power, depot charging systems such as bus charging stations require much more energy. The high-power load as well as the continuous

operation of charging systems throughout the day and night place extreme demands on cables. High quality reeling cables are therefore indispensable.

Reeling cables must be extremely resistant: High current loads and a continuous day and night operation place extreme demands on the cables.

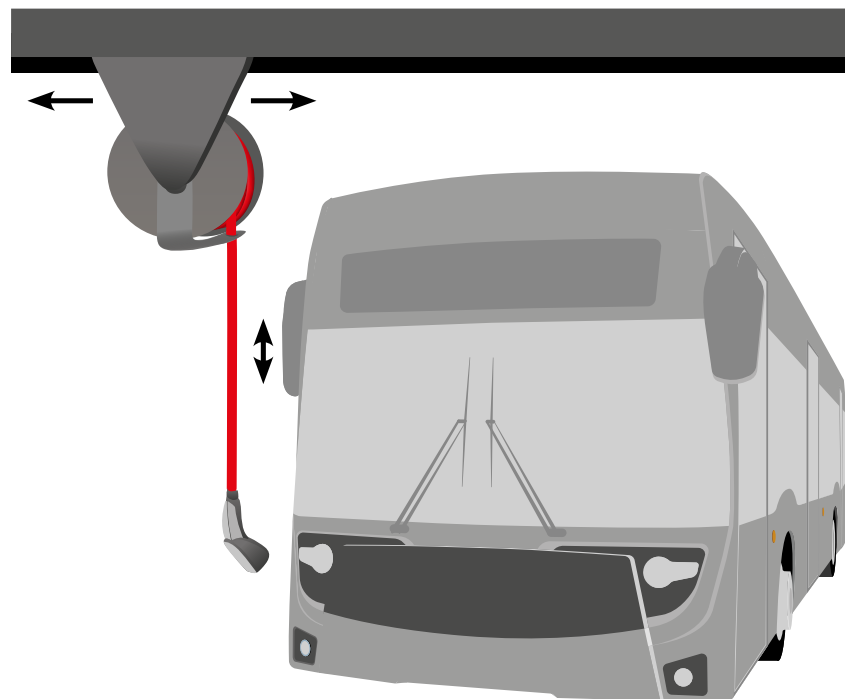

ALWAYS VISIBLE

HELUPOWER® REFLECT & HELUPOWER® GLOW are perfect companions when it comes to charging in the dark. Because of their glow, the charging cables are more visible, less likely to be damaged and eliminate „tripping hazards“.

How do we make our cables shine?

- By using a yellow signal colour for the cable sheath
- With the aid of a reflective foil under a transparent outer sheath
- With fluorescent elements in the outer sheath (by radiation with UV light, the cable glows in the dark)



**Enquiry form for
reeling cables
Find on page 81**

Charging Technology for Buses & Trucks

SUSTAINABLE LOCAL PUBLIC TRANSPORT

Fewer emissions, greater driving comfort and lower operation and maintenance costs in the long term—these are the reasons why electromobility is popular in the design of public transport. More and more major European cities are turning to fully electric vehicles. Battery powered buses can be charged in

various ways: overnight in depots with a plug system, with top-down pantographs, with overhead wires or by induction at individual stops. All these charging methods require reliable and robust cables, which we offer in a wide variety of designs as part of our product portfolio.

POWER ELECTRONICS: THE HEART OF DC CHARGING TECHNOLOGY

High energy capacities pose great challenges to the supply network for charging systems. As can be seen in the diagram to the right, it is even more important that the power electronics, the heart of the DC charging station, function efficiently and reliably. Depending on the power class, a charging station must currently provide up to 600 amps to a power consumer (we use a bus as the energy consumer in this example). The larger the fleet of electric vehicles, the higher the demand for power and the greater the need for operators to adapt cable dimensions accordingly. There is a prerequisite for functioning power electronics: the direct current generated must be available at all times at each charging device and at the corresponding

contact system (with and without plug). Our high performance, resilient and highly flexible cables and wires are particularly in demand for these applications. They must function perfectly in a confined space with a maximum current carrying capacity under mechanical stress. For charging devices in public places, such as airports or parking garages, we offer halogen-free cables and conductors (with corresponding global approvals if required). For a secure communication of the charging systems, we have various Bus and Ethernet cables available, both in copper and with fibre optic technology (also for direct installation in the ground).

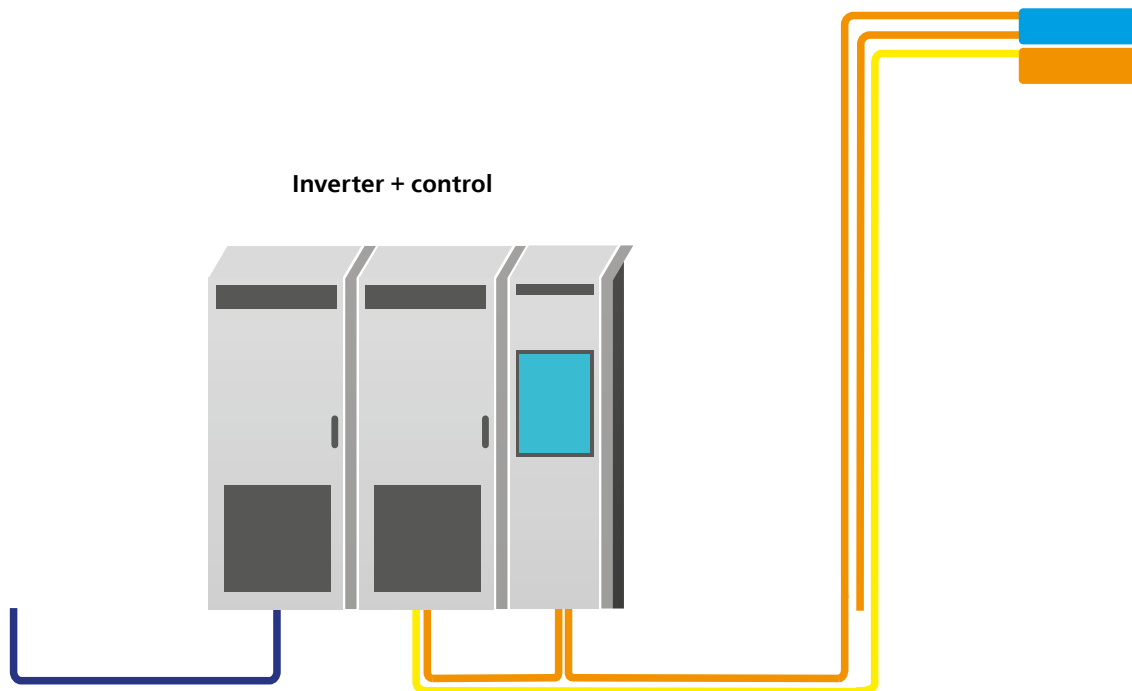

— Highly flexible power cables

Single 600 / Single 600-CY
 Single 602 RC / 602-RC-CY UL/CSA
 HELUPOWER® 1000 RV-K
 HELUPOWER® H07RN-F LS0H
 NSGAFÖU / NSGAFÖU orange
 JZ-600 / JZ-600-Y-CY
 HELUTHERM® 145 / THERMFLEX® 145
 HELUWIND® WK POWERLINE ALU

— BUS cables

CAN-Bus / Profibus L2 (direct burial optional)
 Fiber optic raw cable and assemblies
 Hybrid cable

— Accessories

Protection tubes, cable glands, cable lugs, crimping tools

— Ground cable

Medium-voltage
 Low-voltage
 Corrugated tube in orange for cable protection

TOP-DOWN AND UP-DOWN PANTOGRAPH

Within the route network, the buses are charged at regular intervals via a pantograph. The charging time depends on battery size, bus size, route length, traffic, and climatic conditions. Since pantographs are very compact, the available space should be used optimally. For this complex field of application, we offer special,

highly flexible cables made of copper and aluminium. Due to the use of high-quality insulation materials, they have a high current-carrying capacity and a small outer diameter. In this brochure you will find the right cables for your needs (also in a shielded version for increasing EMC requirements).

Up-down pantograph:

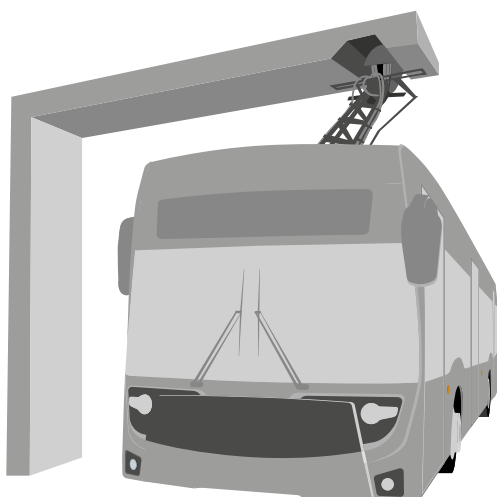

Top-down pantograph:

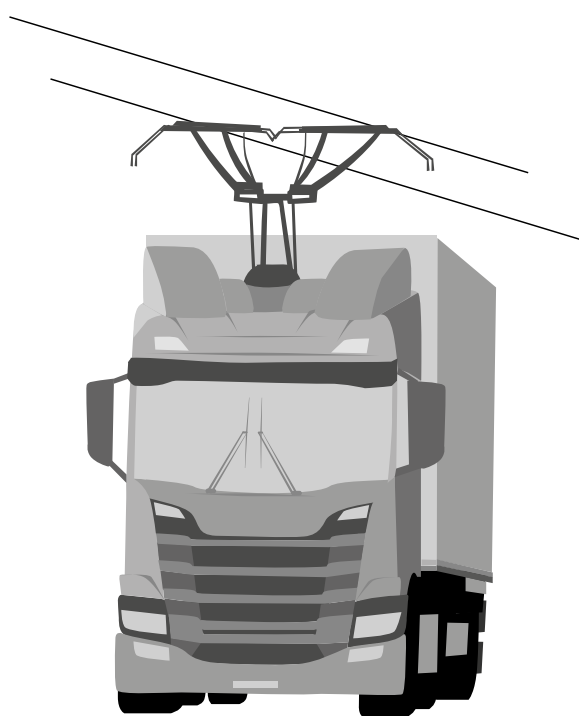
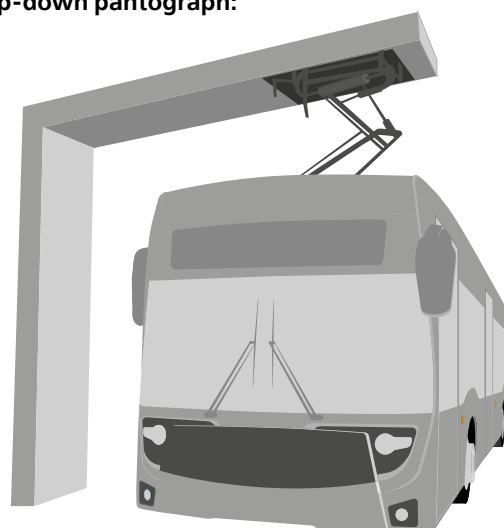

OVERHEAD LINE

When the battery charge level reaches the red zone, the electric bus drives to the next designated charging station and parks under an overhead line. Then the charging process begins. Current collectors mounted on the roof of the bus pick up the direct current via the overhead line.

WIRED PLUG-IN CHARGING SYSTEMS:

Wired plug-in charging systems are used in service yards and bus depots. With high charging rates, even larger bus fleets can conveniently charge their batteries here overnight. CCS-2 connectors (Combined

Charging System; supports AC, DC and fast charging) allow vehicles to be plugged in easily and quickly. As soon as the batteries are green again, the bus can continue its fixed route.

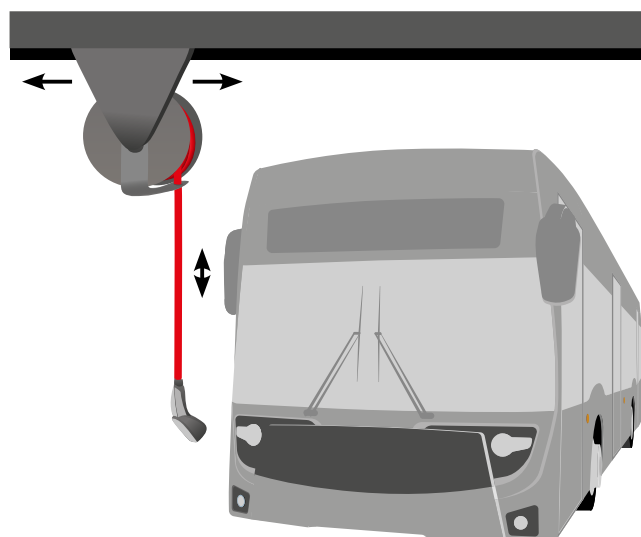

INDUCTIVE CHARGING

With inductive, contactless charging, the energy is transferred via a magnetic field. This is how it works: One coil is permanently installed in the floor of the bus stop, while the other coil is placed in the floor of the vehicle. The closer and more accurately the coils are positioned on top of each other, the greater the efficiency of the charging process.

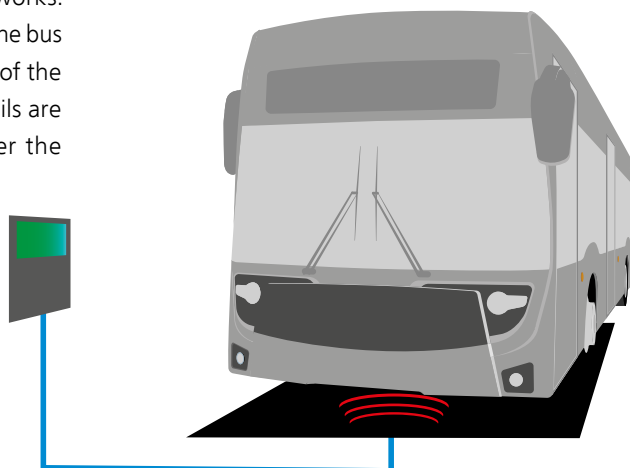

Hybrid Cables

MULTIPLE FUNCTIONS IN JUST ONE CABLE: THE HYBRID CABLE TECHNIQUE SIMPLIFIES HANDLING

Space-saving, efficient and perfectly adapted to every application: Hybrid cables are particularly useful when several functions are to be combined in a single cable. Since users only have to connect one cable instead of several, this solution also simplifies handling and wiring. This is why single-cable technology is becoming increasingly popular in many industries. Hybrid cables are also increasingly being used in modern charging technology: They are used, for example, at charging stations

for electric vehicles to connect the inverter/control panel and DC charging station. The crucial factors here are reliable and interference-free data transmission and an optimal energy supply. Extensive testing as well as the use of perfectly matched materials are further advancing hybrid cable technology. The current state of technology already allows for the combination of copper, aluminium and optical fibres in hybrid cables.

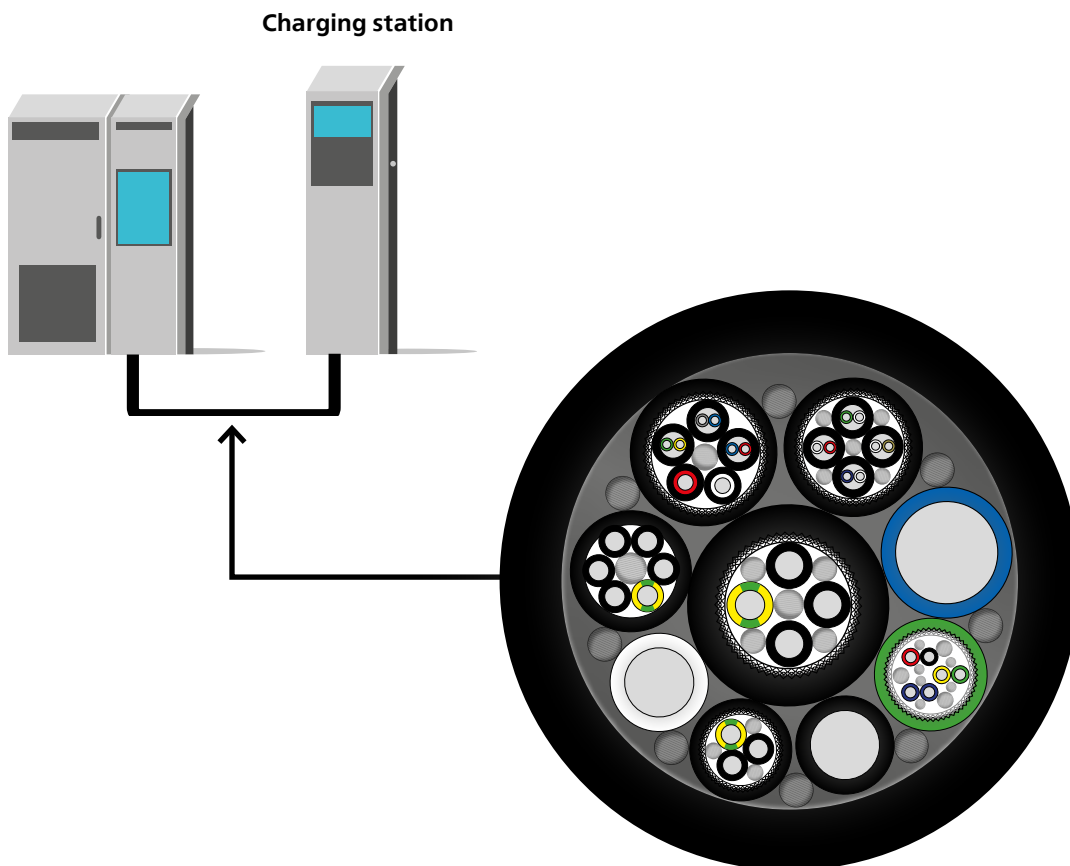

Wireless Charging: The Inductive Charging Method

„WIRELESS“ CHARGING – A TECHNOLOGY TREND

Smartphones laid the foundations for contactless, wireless battery charging. It was only logical that maritime, industrial and urban solutions would follow this technology trend. The new inductive charging process makes contactless, highly efficient charging possible: for example, for passenger ferries with a fixed route, electric cars, industrial trucks and for

bicycles and this with charging power from 3.7 to 22 kW. However, all these applications still need cables. For their infrastructure in particular, inductive charging systems require extremely heavy-duty, reliable cables and conductors, which we can manufacture to customer specifications.

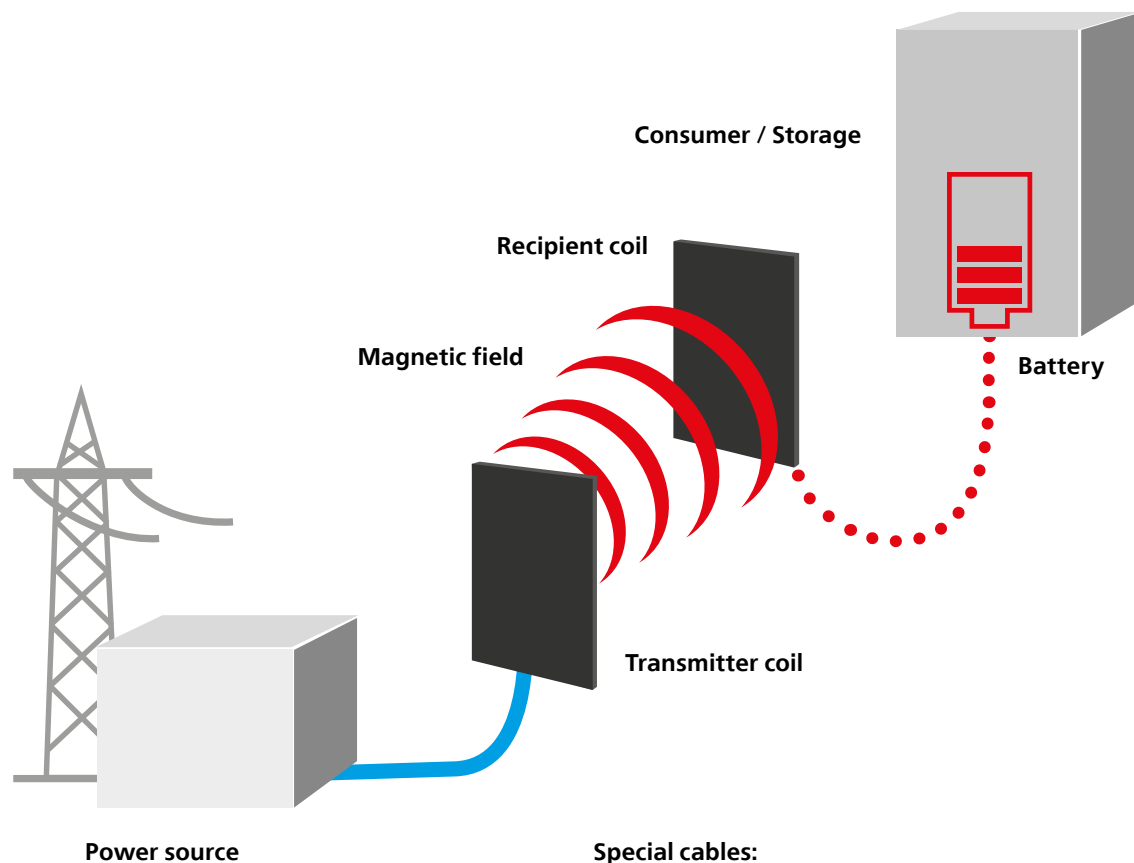

Special cables:

Cores: high-frequency lacquer strand
Sheath: PVC / PUR / optional PE for direct burial
Flat and round cable versions possible

Wireless Charging Application

FERRIES

Inductive charging in maritime applications: The first pilot projects are leading the way as good examples and expose the limits of the combustion engine. With the new technology, ferries charge their batteries within a very short time while keeping to their timetable. On scheduled routes, the battery is charged

whenever passengers board and disembark. The battery size and the charging time depend on the planned route; once the route is clearly defined, the concept of inductive charging is precisely adapted to the needs of the particular ferry.

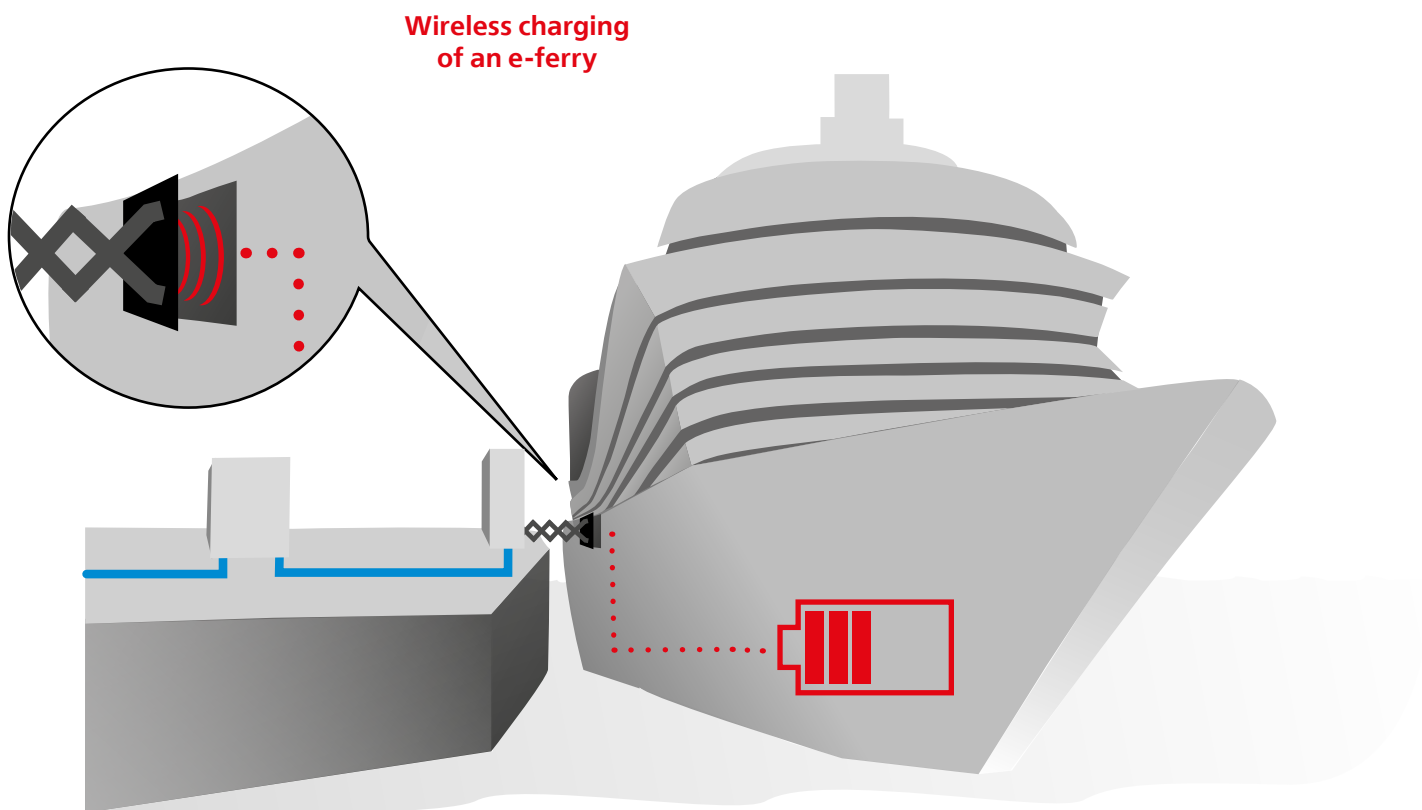

AUTOMOBILES

Electric vehicle registrations continue to rise worldwide. More and more parking spaces with charging points are being built in front of supermarkets or in popular shopping areas and streets. A new approach to charging electric cars involves inductive charging stations that are installed in the ground. The vehicles

simply park in the charging zone and are easily charged without contact. Taxi stands are a good example of this: A taxi driver covers a certain distance with passengers and then stops at a defined charging zone. Once the charge level is back in the green zone, it heads to its next destination.

Wireless charging of an e-automobile

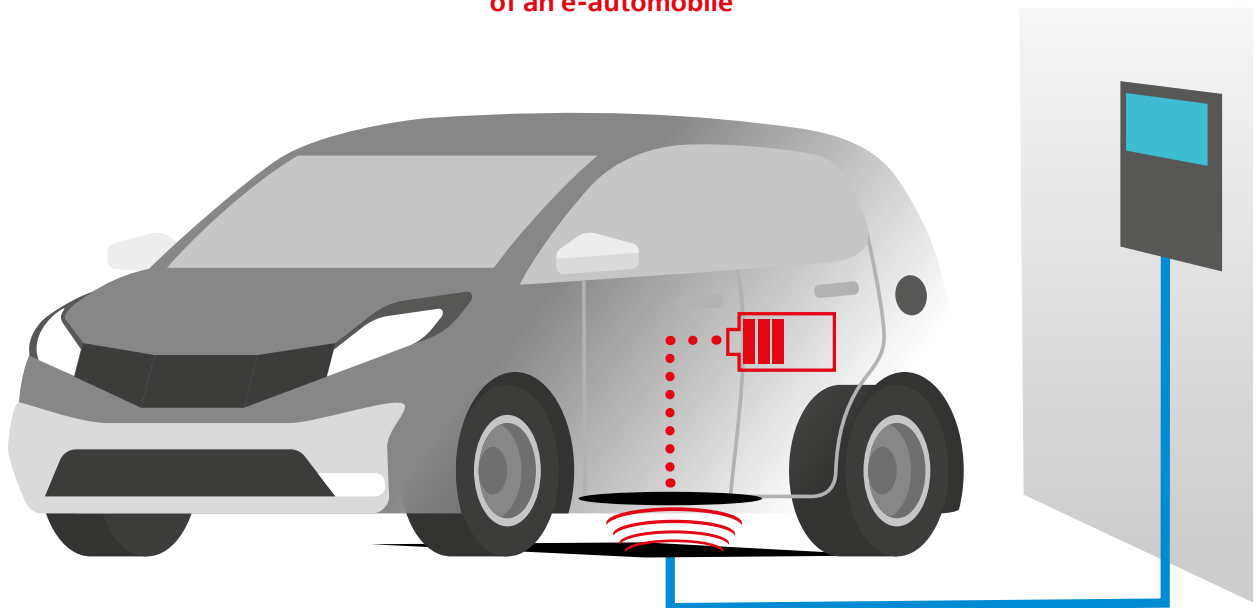

LOGISTICS

Another example of resource-friendly electrification is inductive charging for industrial trucks in logistics. Whether pallet trucks, forklifts or driverless transport systems – they can all be charged inductively in the future. The idea – In regular, scheduled cycles, they

stop to rest at the designated charging stations. The goal – to optimise the utilisation and efficiency of the fleet. Sustainable solutions at airports, logistics centres and container ports will be the trend of the future.

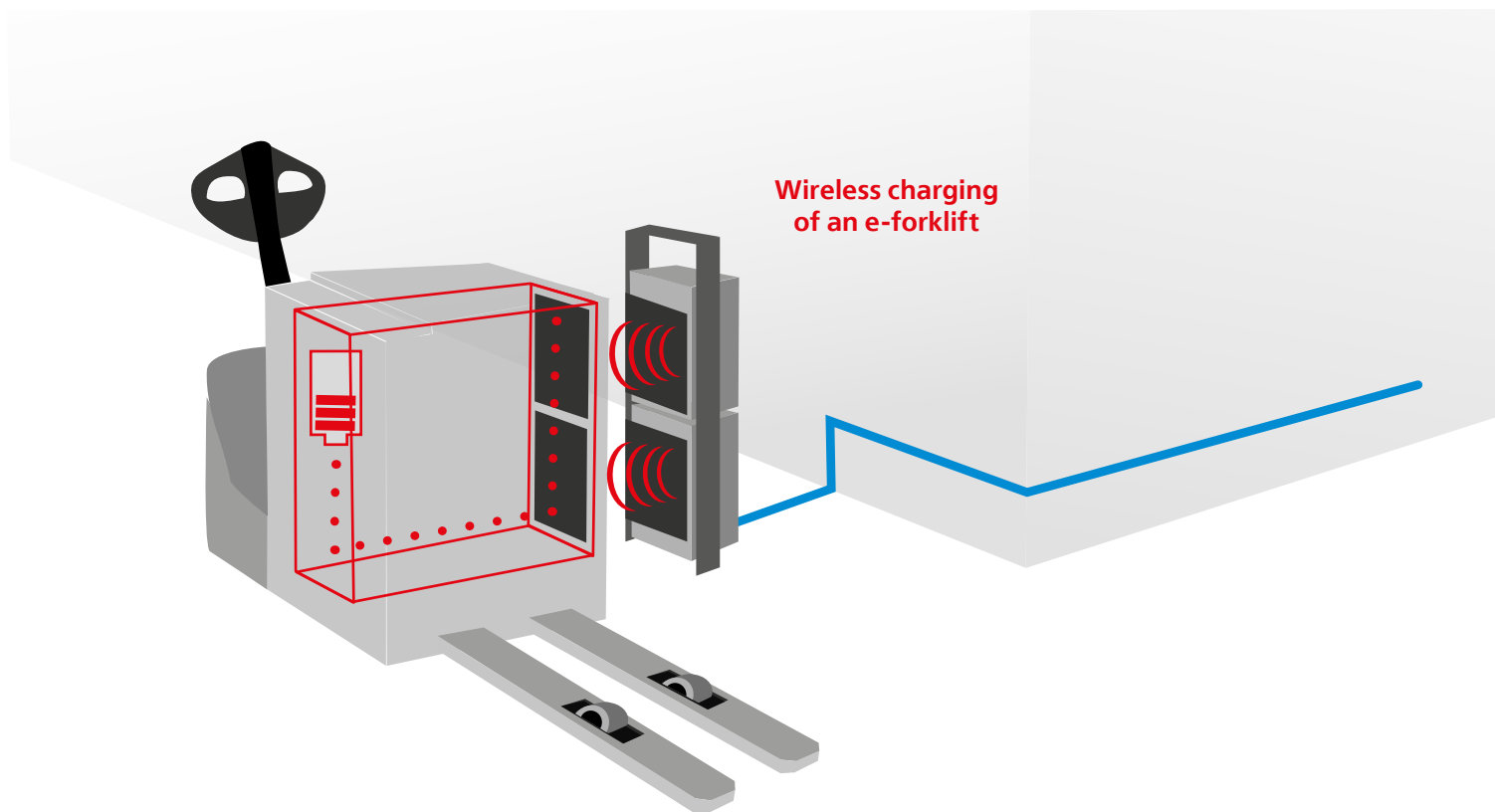

BIKE-CHARGING

More and more people riding e-bikes. The boom has probably not yet reached its peak. This trend is not only creating a new dynamic among cyclists themselves, but also among cities, municipalities and manufacturers in the industry, who are now offering new charging methods for electric two-wheelers. „Charging boxes“

allow the e-bike to be charged conventionally by plug and cable, or by induction. The front wheel latches into the charging station and is locked. Depending on the manufacturer, an app can be used to start and end the charging process very easily.

**Bicycle: charging
with or without cable**

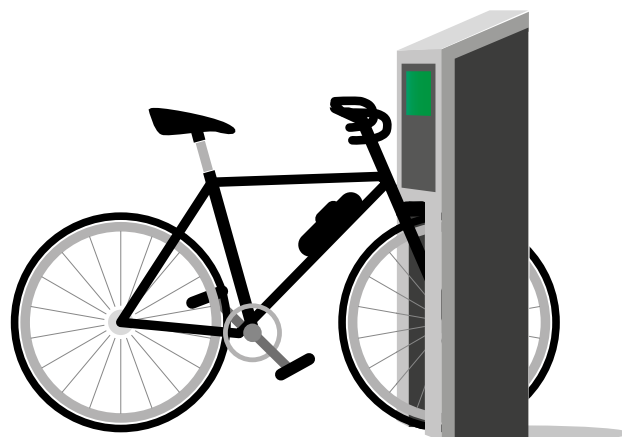
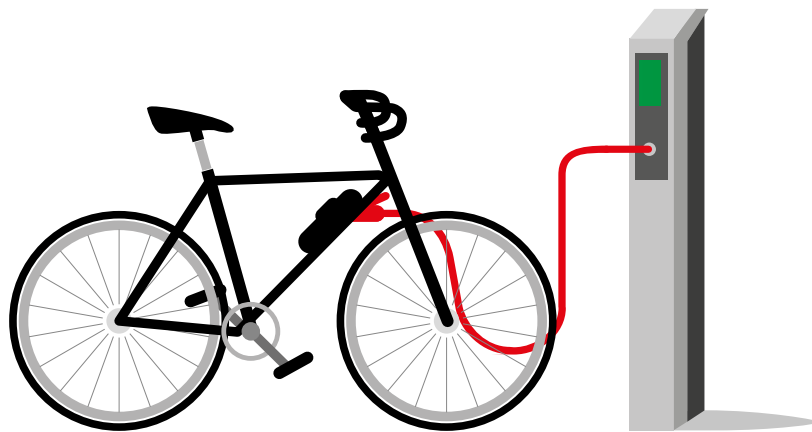

Single 600-J / Single 600-O

600 V

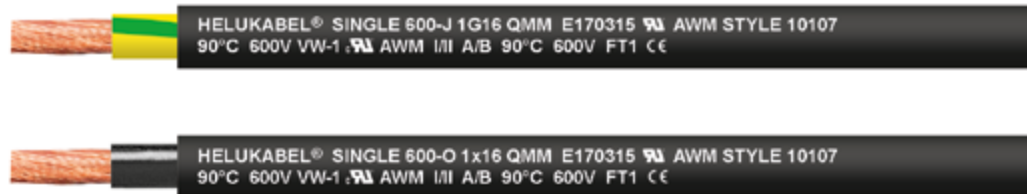

TECHNICAL DATA

PVC sheathed single core cable acc. to UL-Std. 758 (AWM) Style 10107, CSA-Std. C22.2 No. 210 - AWM I/II A/B, in alignment with DIN VDE 0285-525-2-31 / DIN EN 50525-2-31

Temperature range	flexible -5°C to +90°C fixed -40°C to +90°C
Permissible operating temperature of the conductor	+90°C
Nominal voltage	VDE AC U ₀ /U 600/1000 V UL (AWM) AC 600 V
Test voltage	4000 V
Breakdown voltage	8000 V
Minimum bending radius	flexible 7.5x Outer-Ø fixed 4x Outer-Ø

■ CABLE STRUCTURE

- Copper wire bare, finely stranded acc. to DIN VDE 0295 Class 5 / IEC 60228 Class 5
- Core insulation: Special-PVC acc. to UL-Std. 1581
- Core identification: see table
- G = with protective conductor GN-YE, x = without protective conductor
- Outer sheath: PVC acc. to DIN VDE 0207-5 (compound type YM5), UL-Std. 1581
- Sheath colour: black (RAL 9005)
- Length marking: in metres

■ PROPERTIES

- resistant to: UV radiation
- largely resistant to: oil, for details, see "Technical Information"
- for outdoor use
- the materials used during manufacturing are cadmium-free, contain no silicone and are free from substances harmful to the wetting properties of lacquers

■ TESTS

- flame-retardant acc. to DIN VDE 0482-332-1-2 / DIN EN 60332-1-2 / IEC 60332-1-2, UL VW-1, CSA FT1

■ APPLICATION

PVC sheathed single core cable suitable for medium mechanical stress with free movement, without tensile stress and without forced motion control in dry, damp and wet rooms, as well as outdoors (fixed installation). May not be laid directly in soil or water. This two-standard sheathed single core cables are preferably used in export-oriented mechanical engineering on machine tools, production lines and in plant construction.

■ NOTES

- the conductor is metrically (mm²) constructed, AWG numbers are approximated, and are for reference only

Single 600-J, Core identification: green-yellow

Part no.	No. cores x cross-sec. mm ²	AWG, approx.	Outer Ø mm, approx.	Cu-weight kg/km	Weight kg/km, approx.
10881	1 G 6	10	7.8	58.0	118.0
10883	1 G 10	8	9.0	96.0	180.0
10885	1 G 16	6	10.0	154.0	250.0
10887	1 G 25	4	11.4	240.0	370.0
10889	1 G 35	2	13.0	336.0	490.0
10891	1 G 50	1	15.6	480.0	665.0
10893	1 G 70	2/0	17.9	672.0	910.0
10895	1 G 95	3/0	19.5	912.0	1195.0
10897	1 G 120	4/0	22.3	1152.0	1545.0
10899	1 G 150	250 kcmil	25.0	1440.0	1750.0
10901	1 G 185	350 kcmil	28.6	1776.0	2320.0
10903	1 G 240	450 kcmil	31.7	2304.0	2960.0

Single 600-O, Core identification: black

Part no.	No. cores x cross-sec. mm ²	AWG, approx.	Outer Ø mm, approx.	Cu-weight kg/km	Weight kg/km, approx.
10882	1 x 6	10	7.8	58.0	118.0
10884	1 x 10	8	9.0	96.0	180.0
10886	1 x 16	6	10.0	154.0	250.0
10888	1 x 25	4	11.4	240.0	370.0
10890	1 x 35	2	13.0	336.0	490.0
10892	1 x 50	1	15.6	480.0	665.0
10894	1 x 70	2/0	17.9	672.0	910.0
10896	1 x 95	3/0	19.5	912.0	1195.0
10898	1 x 120	4/0	22.3	1152.0	1545.0
10900	1 x 150	250 kcmil	25.0	1440.0	1750.0
10902	1 x 185	350 kcmil	28.6	1776.0	2320.0
10904	1 x 240	450 kcmil	31.7	2304.0	2960.0

Single 600-CY-J / Single 600-CY-O

600 V, EMC-preferred type



TECHNICAL DATA

PVC sheathed single core cable acc. to UL-Std. 758 (AWM) Style 10107, CSA-Std. C22.2 No. 210 - AWM I/II A/B, in alignment with DIN VDE 0285-525-2-31 / DIN EN 50525-2-31

Temperature range	flexible -5°C to +90°C fixed -40°C to +90°C
Permissible operating temperature of the conductor	+90°C
Nominal voltage	VDE AC U ₀ /U 600/1000 V UL (AWM) AC 600 V
Test voltage	4000 V
Breakdown voltage	8000 V
Coupling resistance	at 30 MHz, approx. 250 Ohm/ km
Minimum bending radius	flexible 7.5x Outer-Ø fixed 4x Outer-Ø

CABLE STRUCTURE

- Copper wire bare, finely stranded acc. to DIN VDE 0295 Class 5 / IEC 60228 Class 5
- Core insulation: Special-PVC acc. to UL-Std. 1581
- Core identification: see table
- G = with protective conductor GN-YE, x = without protective conductor
- Screen: braided screen of tinned copper wires, approx. coverage 85%
- Outer sheath: PVC acc. to DIN VDE 0207-5 (compound type YM5), UL-Std. 1581
- Sheath colour: black (RAL 9005)
- Length marking: in metres

PROPERTIES

- resistant to: UV radiation
- largely resistant to: oil, for details, see "Technical Information"
- for outdoor use
- the materials used during manufacturing are cadmium-free, contain no silicone and are free from substances harmful to the wetting properties of lacquers

TESTS

- flame-retardant acc. to DIN VDE 0482-332-1-2 / DIN EN 60332-1-2 / IEC 60332-1-2, UL VW-1, CSA FT1

APPLICATION

PVC sheathed single core cable suitable for medium mechanical stress with free movement, without tensile stress and without forced motion control in dry, damp and wet rooms, as well as outdoors (fixed installation). May not be laid directly in soil or water. This two-standard sheathed single core cables are preferably used in export-oriented mechanical engineering on machine tools, production lines and in plant construction. These copper screened cables are ideally suited for interference-free data signal transmission in measurement and control technology. EMC = Electromagnetic Compatibility; in order to optimise EMC properties, we recommend a double-sided and all-round large contact area of the copper braiding.

NOTES

- the conductor is metrically (mm²) constructed, AWG numbers are approximated, and are for reference only

Single 600-CY-J, Core identification: green-yellow

Part no.	No. cores x cross-sec. mm ²	AWG, approx.	Outer Ø mm, approx.	Cu-weight kg/km	Weight kg/km, approx.
10910	1 G 6	10	7.8	72.0	140.0
10912	1 G 10	8	9.4	130.0	230.0
10914	1 G 16	6	10.4	190.0	300.0
10916	1 G 25	4	12.0	288.0	420.0
10918	1 G 35	2	14.4	405.0	615.0
10920	1 G 50	1	16.4	560.0	825.0
10922	1 G 70	2/0	18.5	780.0	1090.0
10924	1 G 95	3/0	20.1	1030.0	1395.0
10926	1 G 120	4/0	23.0	1285.0	1770.0
10928	1 G 150	250 kcmil	26.1	1570.0	1930.0
10930	1 G 185	350 kcmil	29.3	1940.0	2635.0
10932	1 G 240	450 kcmil	32.2	2530.0	3380.0

Single 600-CY-O, Core identification: black

Part no.	No. cores x cross-sec. mm ²	AWG, approx.	Outer Ø mm, approx.	Cu-weight kg/km	Weight kg/km, approx.
10911	1 x 6	10	7.8	72.0	140.0
10913	1 x 10	8	9.4	130.0	230.0
10915	1 x 16	6	10.4	190.0	300.0
10917	1 x 25	4	12.0	288.0	420.0
10919	1 x 35	2	14.4	405.0	615.0
10921	1 x 50	1	16.4	560.0	825.0
10923	1 x 70	2/0	18.5	780.0	1090.0
10925	1 x 95	3/0	20.1	1030.0	1395.0
10927	1 x 120	4/0	23.0	1285.0	1770.0
10929	1 x 150	250 kcmil	26.1	1570.0	1930.0
10931	1 x 185	350 kcmil	29.3	1940.0	2635.0
10933	1 x 240	450 kcmil	32.2	2530.0	3380.0

Single 602-RC-J / Single 602-RC-O

90°C at conductor / enhanced current carrying capacity, 600 V



TECHNICAL DATA

PVC sheathed single core cable acc. to UL-Std. 758 (AWM) Style 10107, CSA-Std. C22.2 No. 210 - AWM I/II A/B, in alignment with DIN VDE 0285-525-2-31 / DIN EN 50525-2-31

Temperature range	flexible -5°C to +90°C fixed -40°C to +90°C
Permissible operating temperature of the conductor	+90°C
Nominal voltage	VDE AC U ₀ /U 600/1000 V UL (AWM) AC 600 V
Test voltage	4000 V
Breakdown voltage	8000 V
Minimum bending radius	flexible 7.5x Outer-Ø fixed 3x Outer-Ø

- largely resistant to: oil
- for outdoor use
- suitable for use in drag chains
- the materials used during manufacturing are cadmium-free, contain no silicone and are free from substances harmful to the wetting properties of lacquers

TESTS

- flame-retardant acc. to DIN VDE 0482-332-1-2 / DIN EN 60332-1-2 / IEC 60332-1-2, UL VW-1, CSA FT1

APPLICATION

High flexible special single core cable for drag chains are used for flexible use for medium mechanical stresses with free movement without tensile stress or forced movements in dry and moist locations as well as for outdoor use (fixed installation). These two-norm cables primarily designed for exportorientated machinery manufacturer for flexible applications in machineries, machine tools, robot technics, for movable automated machinery parts. RC= Robotics Cable

NOTES

- the conductor is metrically (mm²) constructed, AWG numbers are approximated, and are for reference only
- for use in energy supply systems:
 - 1) the assembly instructions must be observed
 - 2) for further application parameters, please refer to the selection tables
 - 3) for special applications, we recommend contacting us and using our data entry form for energy supply systems

CABLE STRUCTURE

- Copper wire bare, extra finely stranded acc. to DIN VDE 0295 Class 6 / IEC 60228 Class 6
- Core insulation: Special-PVC acc. to UL-Std. 1581
- Core identification: see table
- G = with protective conductor GN-YE, x = without protective conductor
- Outer sheath: PVC acc. to DIN VDE 0207-5 (compound type YM5), UL-Std. 1581
- Sheath colour: black (RAL 9005)
- Length marking: in metres

PROPERTIES

- resistant to: UV radiation

Single 602-RC-J, Core identification: green-yellow

Part no.	No. cores x cross-sec. mm ²	AWG, approx.	Outer Ø mm, approx.	Cu-weight kg/km	Weight kg/km, approx.
69601	1 G 10	8	9.4	96.0	180.0
69603	1 G 16	6	10.5	154.0	250.0
69605	1 G 25	4	11.6	240.0	370.0
69607	1 G 35	2	14.0	336.0	490.0
69609	1 G 50	1	16.6	480.0	665.0
69611	1 G 70	2/0	18.4	672.0	910.0
69613	1 G 95	3/0	19.6	912.0	1195.0
69615	1 G 120	4/0	23.0	1152.0	1545.0
69617	1 G 150	250 kcmil	25.2	1440.0	1750.0
69619	1 G 185	350 kcmil	29.0	1776.0	2320.0
69621	1 G 240	450 kcmil	32.5	2304.0	2960.0
69623	1 G 300	550 kcmil	36.4	2880.0	3550.0

Single 602-RC-O, Core identification: black

Part no.	No. cores x cross-sec. mm ²	AWG, approx.	Outer Ø mm, approx.	Cu-weight kg/km	Weight kg/km, approx.
69602	1 x 10	8	9.4	96.0	180.0
69604	1 x 16	6	10.5	154.0	250.0
69606	1 x 25	4	11.6	240.0	370.0
69608	1 x 35	2	14.0	336.0	490.0
69610	1 x 50	1	16.6	480.0	665.0
69612	1 x 70	2/0	18.4	672.0	910.0
69614	1 x 95	3/0	19.6	912.0	1195.0
69616	1 x 120	4/0	23.0	1152.0	1545.0
69618	1 x 150	250 kcmil	25.2	1440.0	1750.0
69620	1 x 185	350 kcmil	29.0	1776.0	2320.0
69622	1 x 240	450 kcmil	32.5	2304.0	2960.0
69624	1 x 300	550 kcmil	36.4	2880.0	3550.0

Single 602-RC-CY-J / Single 602-RC-CY-O



90°C at conductor / enhanced current carrying capacity, 600 V,
EMC-preferred type



TECHNICAL DATA

PVC sheathed single core cable acc. to UL-Std. 758 (AWM) Style 10107, CSA-Std. C22.2 No. 210 - AWM I/II A/B, in alignment with DIN VDE 0285-525-2-31 / DIN EN 50525-2-31

Temperature range	flexible -5°C to +90°C fixed -40°C to +90°C
Permissible operating temperature of the conductor	+90°C
Nominal voltage	VDE AC U ₀ /U 600/1000 V UL (AWM) AC 600 V
Test voltage	4000 V
Breakdown voltage	8000 V
Coupling resistance	at 30 MHz, approx. 250 Ohm/km
Minimum bending radius	flexible 7.5x Outer-Ø fixed 3x Outer-Ø

CABLE STRUCTURE

- Copper wire bare, extra finely stranded acc. to DIN VDE 0295 Class 6 / IEC 60228 Class 6
- Core insulation: Special-PVC acc. to UL-Std. 1581
- Core identification: see table
- G = with protective conductor GN-YE, x = without protective conductor
- Screen: braided screen of tinned copper wires, approx. coverage 85%
- Outer sheath: PVC acc. to DIN VDE 0207-5 (compound type YM5), UL-Std. 1581
- Sheath colour: orange (RAL 2003) / acc. to. DESINA
- Length marking: in metres

PROPERTIES

- largely resistant to: oil
- suitable for use in drag chains
- the materials used during manufacturing are cadmium-free, contain no silicone and are free from substances harmful to the wetting properties of lacquers

TESTS

- flame-retardant acc. to DIN VDE 0482-332-1-2 / DIN EN 60332-1-2 / IEC 60332-1-2, UL VW-1, CSA FT1

APPLICATION

High flexible special single core screened cables for drag chains are used for flexible use for medium mechanical stresses with free movement without tensile stress or forced movements in dry, moist and wet rooms. These two-norm cables primarily designed for exportorientated machinery manufacturer for flexible applications in machineries, machine tools, robot technics, for movable automated machinery parts. These screened cables are particularly suitable for the interference-free transmission in instrumentation and control engineering applications (electromagnetic compatibility). EMC= Electromagnetic compatibility; to optimize the EMC features we recommend a large round contact of the copper braiding on both ends. RC= Robotics Cable

NOTES

- the conductor is metrically (mm²) constructed, AWG numbers are approximated, and are for reference only
- for use in energy supply systems:
 - 1) the assembly instructions must be observed
 - 2) for further application parameters, please refer to the selection tables
 - 3) for special applications, we recommend contacting us and using our data entry form for energy supply systems

Single 602-RC-CY-J, Core identification: green-yellow

Part no.	No. cores x cross-sec. mm ²	AWG, approx.	Outer Ø mm, approx.	Cu-weight kg/km	Weight kg/km, approx.
69631	1 G 10	8	10.0	130.0	230.0
69633	1 G 16	6	11.1	190.0	300.0
69635	1 G 25	4	12.3	288.0	420.0
69637	1 G 35	2	14.7	405.0	615.0
69639	1 G 50	1	17.2	560.0	825.0
69641	1 G 70	2/0	19.0	780.0	1090.0
69643	1 G 95	3/0	21.2	1030.0	1395.0
69645	1 G 120	4/0	23.6	1285.0	1770.0
69647	1 G 150	250 kcmil	25.8	1570.0	1930.0
69649	1 G 185	350 kcmil	29.8	1940.0	2635.0
69651	1 G 240	450 kcmil	33.5	2530.0	3380.0
69653	1 G 300	550 kcmil	38.0	3140.0	4120.0

Single 602-RC-CY-O, Core identification: black

Part no.	No. cores x cross-sec. mm ²	AWG, approx.	Outer Ø mm, approx.	Cu-weight kg/km	Weight kg/km, approx.
69632	1 x 10	8	10.0	130.0	230.0
69634	1 x 16	6	11.1	190.0	300.0
69636	1 x 25	4	12.3	288.0	420.0
69638	1 x 35	2	14.7	405.0	615.0
69640	1 x 50	1	17.2	560.0	825.0
69642	1 x 70	2/0	19.0	780.0	1090.0
69644	1 x 95	3/0	21.2	1030.0	1395.0
69646	1 x 120	4/0	23.6	1285.0	1770.0
69648	1 x 150	250 kcmil	25.8	1570.0	1930.0
69650	1 x 185	350 kcmil	29.8	1940.0	2635.0
69652	1 x 240	450 kcmil	33.5	2530.0	3380.0
69654	1 x 300	550 kcmil	38.0	3140.0	4120.0

HELUPOWER® H07RN-F LSOH

oil-resistant, implementable up to a water depth of 100 m



HELUKABEL® HELUPOWER® H07RN-F LSOH <HAR> CE

TECHNICAL DATA

Rubber connection cable acc. to DIN VDE 0285-525-2-21 / DIN EN 50525-2-21

Temperature range flexible -40°C to +90°C
fixed -50°C to +90°C

Permissible operating temperature of the conductor +90°C

Short-circuit temperature at conductor +250°C

Nominal voltage AC U₀/U 450/750 V

Max. permissible operating voltage
alternating current (AC) conductor/earth 476 V
three-phase alternating current (AC) conductor/conductor 825 V
direct current (DC) conductor/earth 619 V
direct current (DC) conductor/conductor 1238 V

Test voltage core/core 2500 V

Minimum bending radius flexible 6x Outer-Ø
fixed 4x Outer-Ø

- Sheath colour: black

PROPERTIES

- resistant to: oil, UV radiation, ozone, weathering effects, lubricating oils, greases
- for outdoor use
- halogen-free

TESTS

- halogen-free acc. to DIN VDE 0482-754-1 / DIN EN 60754-1 / IEC 60754-1
- corrosiveness of combustion gases acc. to DIN VDE 0482-754-2 / DIN EN 60754-2 / IEC 60754-2
- flame-retardant acc. to DIN VDE 0482-332-1-2 / DIN EN 60332-1-2 / IEC 60332-1-2
- smoke density acc. to DIN VDE 0482-1034-1+2 / DIN EN 61034-1+2 / IEC 61034-1+2
- oil-resistant acc. to DIN VDE 0473-811-404 / DIN EN 60811-404 / IEC 60811-404
- ozone-resistant acc. to DIN VDE 0473-811-403 / DIN EN 60811-403

APPLICATION

Halogen-free rubber sheathed cables for use with medium mechanical stress in dry, damp, wet rooms and outdoors. Can only be used in stagnant waters (also in salt water) up to a water depth of 100 m (AD8) and a water temperature of min. +5°C. When installed in pipes or similar closed systems, the use of the cable is permitted up to and including 1000 V AC voltage or up to 750 V DC voltage against earth.

NOTES

- the conductor is metrically (mm²) constructed, AWG numbers are approximated, and are for reference only

CABLE STRUCTURE

- Copper wire bare, finely stranded acc. to DIN VDE 0295 Class 5 / IEC 60228 Class 5
- Core insulation: Special rubber
- Core identification acc. to DIN VDE 0293-308,
1 core(s): black
2 - 5 core(s): colour coded
7 - 12 core(s): black cores with consecutive labeling in white digits
- Protective conductor: starting with 3 cores,
G = with protective conductor GN-YE, in the outer layer,
x = without protective conductor
- Cores stranded in layers with optimal lay lengths
- Outer sheath: Special rubber

Part no.	No. cores x cross-sec. mm ²	AWG, approx.	Outer-Ø min. - max. mm	Cu-weight kg/km	Weight kg/km, approx.
30737	1 x 1.5	16	5.7 - 6.5	14.4	51.0
30738	1 x 2.5	14	6.3 - 7.2	24.0	67.0
30739	1 x 4	12	7.2 - 8.1	38.0	92.0
30740	1 x 6	10	7.9 - 8.8	58.0	121.0
30741	1 x 10	8	9.5 - 11.5	96.0	186.0
30742	1 x 16	6	10.8 - 13.0	154.0	256.0
30743	1 x 25	4	12.7 - 15.0	240.0	368.0
30744	1 x 35	2	14.3 - 16.5	336.0	485.0
30745	1 x 50	1	16.5 - 19.5	480.0	668.0
30746	1 x 70	2/0	18.6 - 22.5	672.0	905.0
30747	1 x 95	3/0	20.8 - 25.4	912.0	1180.0
30748	1 x 120	4/0	22.8 - 27.6	1152.0	1460.0
30749	1 x 150	300 kcmil	25.2 - 30.3	1440.0	1810.0
30750	1 x 185	350 kcmil	27.6 - 33.0	1776.0	2165.0
30751	1 x 240	500 kcmil	30.6 - 36.3	2304.0	2750.0

Part no.	No. cores x cross-sec. mm ²	AWG, approx.	Outer-Ø min. - max. mm	Cu-weight kg/km	Weight kg/km, approx.
30752	1 x 300	600 kcmil	33.5 - 39.0	2880.0	3271.0
30753	1 x 400	750 kcmil	37.4 - 41.5	3840.0	4286.0
30754	1 x 500	1000 kcmil	41.3 - 46.0	4800.0	5301.0
30755	1 x 630	1250 kcmil	45.5 - 50.0	6048.0	6959.0
30756	2 x 1	18	7.7 - 9.0	19.0	93.0
30757	2 x 1.5	16	8.5 - 9.9	29.0	115.0
30758	2 x 2.5	14	10.2 - 11.7	48.0	165.0
30759	2 x 4	12	11.8 - 13.4	77.0	225.0
30760	2 x 6	10	13.1 - 14.9	115.0	300.0
30761	2 x 10	8	17.7 - 20.0	192.0	550.0
30762	2 x 16	6	20.2 - 22.6	307.0	745.0
30763	2 x 25	4	24.3 - 27.0	480.0	1060.0
30764	3 G 1	18	8.3 - 9.7	29.0	120.0
30765	3 G 1.5	16	9.2 - 10.7	43.0	150.0
30766	3 G 2.5	14	10.9 - 12.5	72.0	200.0

HELUPOWER® H07RN-F LSOH

oil-resistant, implementable up to a water depth of 100 m



Part no.	No. cores x cross-sec. mm ²	AWG, approx.	Outer-Ø min. - max. mm	Cu-weight kg/km	Weight kg/km, approx.
30767	3 G 4	12	12.7 - 14.4	115.0	295.0
30768	3 G 6	10	14.1 - 16.0	173.0	380.0
30769	3 G 10	8	19.1 - 21.5	288.0	675.0
30770	3 G 16	6	21.8 - 24.3	461.0	950.0
30771	3 G 25	4	26.1 - 28.8	720.0	1355.0
30772	3 G 35	2	29.3 - 32.5	1008.0	1765.0
30773	3 G 50	1	34.1 - 37.0	1440.0	2415.0
30774	3 G 70	2/0	38.4 - 40.9	2016.0	3230.0
30775	3 G 95	3/0	43.3 - 47.4	2736.0	4225.0
30776	3 G 120	4/0	47.4 - 53.2	3456.0	5190.0
30777	3 G 150	300 kcmil	52.0 - 57.5	4320.0	6415.0
30778	3 G 185	350 kcmil	57.0 - 62.7	5328.0	7700.0
30779	3 G 240	500 kcmil	65.0 - 71.4	6912.0	9458.0
30780	3 G 300	600 kcmil	72.0 - 78.3	8640.0	11635.0
30781	4 G 1	18	9.2 - 10.7	38.0	145.0
30782	4 G 1.5	16	10.2 - 11.7	58.0	175.0
30783	4 G 2.5	14	12.1 - 13.8	96.0	255.0
30784	4 G 4	12	14.0 - 15.9	154.0	355.0
30785	4 G 6	10	15.7 - 17.7	230.0	485.0
30786	4 G 10	8	20.9 - 23.6	384.0	845.0
30787	4 G 16	6	23.8 - 26.4	614.0	1185.0
30788	4 G 25	4	28.9 - 32.1	960.0	1730.0
30789	4 G 35	2	32.5 - 36.0	1344.0	2250.0

Part no.	No. cores x cross-sec. mm ²	AWG, approx.	Outer-Ø min. - max. mm	Cu-weight kg/km	Weight kg/km, approx.
30790	4 G 50	1	37.7 - 41.5	1920.0	3085.0
30791	4 G 70	2/0	42.7 - 47.1	2688.0	4145.0
30792	4 G 95	3/0	48.4 - 54.9	3648.0	5465.0
30793	4 G 120	4/0	53.0 - 57.5	4608.0	6670.0
30794	4 G 150	300 kcmil	58.0 - 63.6	5760.0	8290.0
30795	4 G 185	350 kcmil	64.0 - 69.7	7104.0	9385.0
30796	5 G 1	18	10.2 - 11.7	48.0	180.0
30797	5 G 1.5	16	11.2 - 12.8	72.0	220.0
30798	5 G 2.5	14	13.3 - 15.1	120.0	310.0
30799	5 G 4	12	15.6 - 17.9	192.0	445.0
30800	5 G 6	10	17.5 - 20.0	288.0	605.0
30801	5 G 10	8	22.9 - 25.7	480.0	1035.0
30802	5 G 16	6	26.4 - 30.0	768.0	1465.0
30803	5 G 25	4	32.0 - 35.4	1200.0	2145.0
30804	5 G 35	2	35.7 - 39.5	1680.0	2579.0
30805	5 G 50	1	41.8 - 47.0	2400.0	3594.0
30806	5 G 70	2/0	47.5 - 52.5	3360.0	4837.0
30807	5 G 95	3/0	54.0 - 58.0	4560.0	6269.0
30808	7 G 1.5	16	14.7 - 17.5	101.0	355.0
30809	7 G 2.5	14	17.1 - 20.0	168.0	498.0
30810	12 G 1.5	16	17.6 - 21.0	173.0	505.0
30811	12 G 2.5	14	20.6 - 24.5	288.0	710.0

HELUWIND® WK DLO, WK DLO-Torsion

2 kV, FT4, VW-1, RHH/RHW-2, UL44



TECHNICAL DATA

Cable for torsion applications in wind turbines

Temperature range	flexible -25°C to +80°C fixed -40°C to +80°C
Nominal voltage	2000 V
Torsion application	only for WK DLO-Torsion +/- 150° per 1m

■ CABLE STRUCTURE

- Special stranded bare copper wire, fine stranded acc. to ASTM-B3
- Insulation: EP
- Separating foil wrap
- Sheath: TPE/CPE
- Sheath colour: black

■ TESTS

- Torsion tested in accordance with HELUKABEL test requirements
- RHH/RHW-2, PRI PRII, CSA RW90, CSA 22.2 No. 38, VW-1, cold impact test, cold bend test, wet or dry per UL44, for CT use
- Flame test CSA FT1, FT4, IEEE 1202

■ APPLICATION

The cable HELUWIND® WK DLO was specifically designed for use in wind turbines up to a nominal voltage of 2 kV. It has been specially developed for torsion applications in wind turbines. We supply the leading wind turbine manufacturers.

■ NOTE

For more information, especially on custom cables, please contact us: wind@helukabel.de

WK DLO 2 kV

Part no.	Cross-section AWG / kcmil	Outer Ø app. mm	Cop. weight kg/km	Weight app. kg / km
703156	14	5.9	22.0	37.0
703157	12	6.3	33.0	69.0
703158	10	7.2	61.0	100.0
702513	8	8.2	82.8	142.0
703159	6	10.1	140.0	200.0
703160	4	11.5	237.0	286.0
703161	2	12.6	339.0	370.0
703162	1	16.1	510.0	637.0
703163	1/0	17.5	465.0	715.0
703862	2/0	18.5	656.0	830.0
703164	3/0	20.2	930.0	1104.0
702863	4/0	21.7	1103.0	1298.0
702514	262 kcmil	24.8	1280.0	1590.0
703165	313 kcmil	26.4	1590.0	1872.0
703166	373 kcmil	28.2	1900.0	2176.0
703167	444 kcmil	30.0	930.0	1104.0
702515	535 kcmil	32.2	2608.0	3046.0
703168	646 kcmil	34.8	3300.0	3600.0
703169	777 kcmil	37.0	3970.0	4290.0
703170	929 kcmil	39.5	4780.0	5144.0
703171	1111 kcmil	44.4	5690.0	6070.0

WK DLO-Torsion 2 kV

Part no.	Cross-section AWG / kcmil	Outer Ø app. mm	Cop. weight kg/km	Weight app. kg / km
709729	8	8.2	82.8	142.0
709730	6	10.1	140.0	200.0
709731	4	11.5	237.0	286.0
709732	2	12.6	339.0	370.0
709733	1	16.1	510.0	637.0
709734	1/0	17.5	465.0	715.0
709735	2/0	18.5	656.0	830.0
709288	3/0	20.2	930.0	1104.0
709289	4/0	21.7	1103.0	1298.0
709290	262 kcmil	24.8	1280.0	1590.0
709291	313 kcmil	26.4	1590.0	1872.0
709292	373 kcmil	28.2	1900.0	2176.0
709293	444 kcmil	30.0	930.0	1104.0
709294	535 kcmil	32.2	2608.0	3046.0
709295	646 kcmil	34.8	3300.0	3600.0
709296	777 kcmil	37.0	3970.0	4290.0
709297	929 kcmil	39.5	4780.0	5144.0
709298	1111 kcmil	44.4	5690.0	6070.0



more information
on page 78

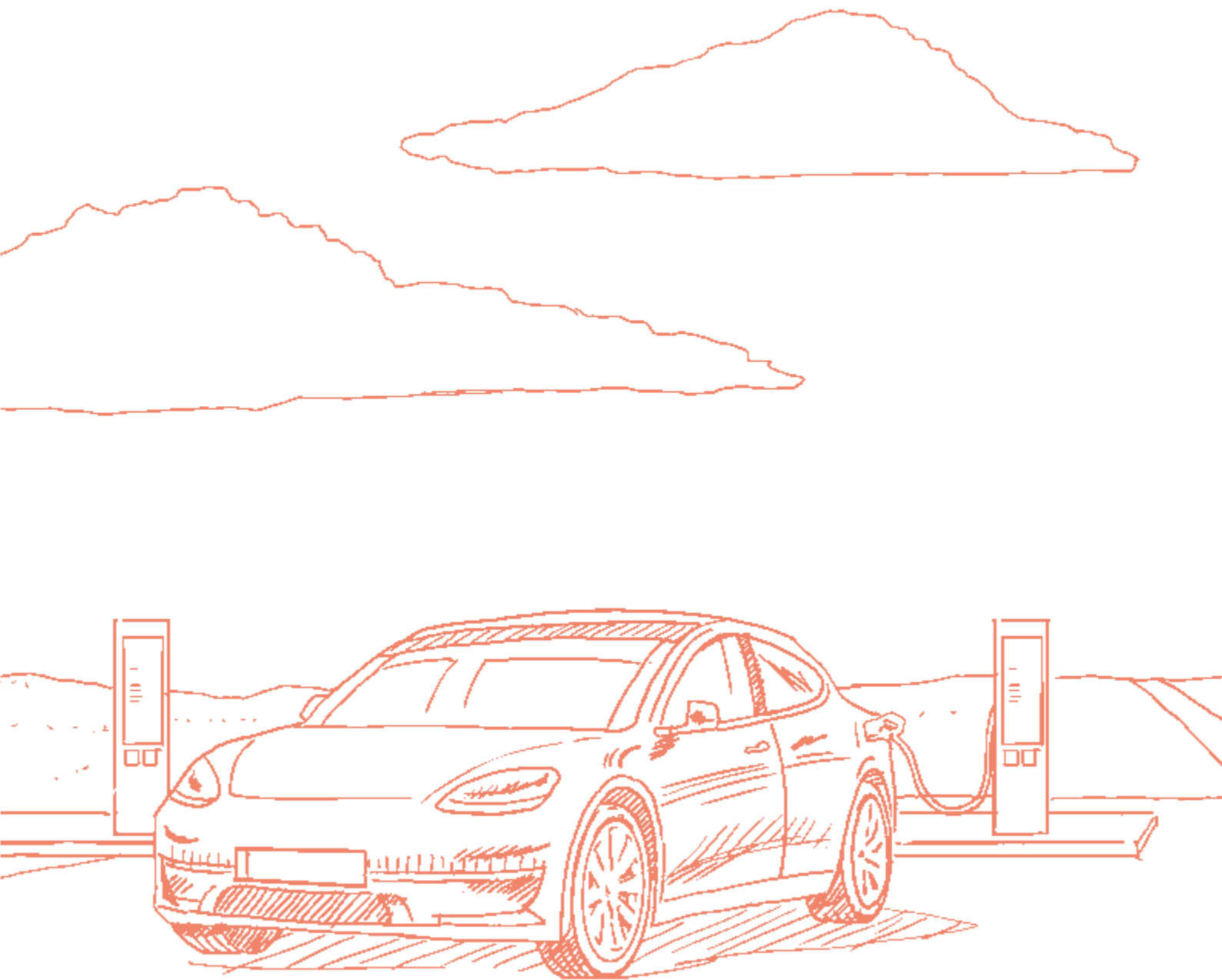

HELUPOWER® 1100-RZ1-K LSOH GREEN

flexible, direct burial, low smoke development, flame-retardant



HELUKABEL® HELUPOWER® 1100-RZ1-K (AS) LSOH GREEN CE

TECHNICAL DATA

Connection cable acc. to UNE 21123-4

Temperature range	flexible 0°C to +90°C fixed -15°C to +90°C
Permissible operating temperature of the conductor	+90°C
Short circuit temperature at the conductor	+250°C (Short circuit temperature max. 5 s)
Nominal voltage	AC U ₀ /U 600/1000 V
Max. permissible operating voltage	alternating current (AC) conductor/earth 700 V three-phase alternating current (AC) conductor/conductor 1200 V direct current (DC) conductor/earth 900 V direct current (DC) conductor/conductor 1800 V
Test voltage core/core	3500 V
Minimum bending radius	<25 mm: 4x Outer-ø 25-50 mm: 5x Outer-ø >50 mm: 6x Outer-ø

- Sheath colour: green
- Length marking: in metres

PROPERTIES

- resistant to: oil, UV radiation
- for outdoor use
- direct burial
- halogen-free
- the materials used during manufacturing are cadmium-free, contain no silicone and are free from substances harmful to the wetting properties of lacquers
- reduced fire propagation, reduced release of corrosive and toxic gases

TESTS

- halogen-free acc. to DIN VDE 0482-754-1 / DIN EN 60754-1 / IEC 60754-1
- corrosiveness of combustion gases acc. to DIN VDE 0482-754-2 / DIN EN 60754-2 / IEC 60754-2
- flame-retardant acc. to DIN VDE 0482-332-1-2 / DIN EN 60332-1-2 / IEC 60332-1-2
- bundle fire test acc. to DIN VDE 0482-332-3-24 / DIN EN 60332-3-24 / IEC 60332-3-24 (Cat. C)
- smoke density acc. to DIN VDE 0482-1034-1+2 / DIN EN 61034-1+2 / IEC 61034-1+2
- oil-resistant acc. to DIN VDE 0473-811-404 / DIN EN 60811-404 / IEC 60811-404
- UV-resistant acc. to UNE 211605
- CPR-class: C_{ca} s1b d1 a1
- Certifications: AENOR

CABLE STRUCTURE

- Copper wire bare, finely stranded acc. to DIN VDE 0295 Class 5 / IEC 60228 Class 5
- Core insulation: XLPE acc. to UNE-HD 603-1 (compound type DIX 3)
- Core identification acc. to DIN VDE 0293-308,
1 core(s): black
2 - 5 core(s): colour coded
- Protective conductor: starting with 3 cores,
G = with protective conductor GN-YE,
x = without protective conductor
- Cores stranded with optimal lay lengths
- Outer sheath: Polyolefin acc. to UNE 21123-4 (compound type DMZ-E)

APPLICATION

Suitable for fixed power supply installations in public and commercial buildings or in power distribution networks where a high degree of safety is required. Suitable for indoor and outdoor use, for laying in tubes and pipes and suitable for direct burial.

Part no.	No. cores x cross-sec. mm ²	AWG, approx.	Outer-ø min - max mm	Cu-weight kg/km	Weight kg/km, approx.
11008092	2 x 1.5		9.0 - 10.4	28.8	105.0
11008093	3 G 1.5		9.5 - 10.8	43.2	120.0
11008094	3 x 1.5		9.5 - 10.8	43.2	120.0
11008095	4 G 1.5		10.2 - 11.6	57.6	142.0
11008096	4 x 1.5		10.2 - 11.6	57.6	142.0
11008097	5 G 1.5		11.0 - 12.4	72.0	165.0
11008098	5 x 1.5		11.0 - 12.4	72.0	165.0
11008118	2 x 2.5		9.8 - 11.3	48.0	137.0
11008119	3 G 2.5		10.3 - 11.8	72.0	161.0
11008120	3 x 2.5		10.3 - 11.8	72.0	161.0
11008121	4 G 2.5		11.1 - 12.7	96.0	195.0
11008122	4 x 2.5		11.1 - 12.7	96.0	195.0
11008123	5 G 2.5		12.1 - 13.6	120.0	225.0

Part no.	No. cores x cross-sec. mm ²	AWG, approx.	Outer-ø min - max mm	Cu-weight kg/km	Weight kg/km, approx.
11008124	5 x 2.5		12.1 - 13.6	120.0	225.0
11008144	2 x 4		11.0 - 12.4	76.8	180.0
11008145	3 G 4		11.6 - 13.0	115.2	215.0
11008146	3 x 4		11.6 - 13.0	115.2	215.0
11008147	4 G 4		12.6 - 14.0	153.6	260.0
11008148	4 x 4		12.6 - 14.0	153.6	260.0
11008149	5 G 4		13.7 - 15.1	192.0	315.0
11008150	5 x 4		13.7 - 15.1	192.0	315.0
11008152	2 x 6		12.0 - 13.6	115.2	230.0
11008153	3 G 6		12.6 - 14.3	172.8	280.0
11008154	3 x 6		12.6 - 14.3	172.8	280.0
11008155	4 G 6		13.8 - 15.5	230.4	350.0
11008156	4 x 6		13.8 - 15.5	230.4	350.0

HELUPOWER® 1100-RZ1-K LSOH GREEN

flexible, direct burial, low smoke development, flame-retardant



Part no.	No. cores x cross-sec. mm ²	AWG, approx.	Outer-ø min - max mm	Cu-weight kg/km	Weight kg/km, approx.	Part no.	No. cores x cross-sec. mm ²	AWG, approx.	Outer-ø min - max mm	Cu-weight kg/km	Weight kg/km, approx.
11008157	5 G 6		15.1 - 16.8	288.0	420.0	11008190	5 x 35		28.6 - 30.6	1680.0	2100.0
11008158	5 x 6		15.1 - 16.8	288.0	420.0	11008191	1 x 50		13.8 - 14.9	480.0	520.0
11008159	1 x 10		8.1 - 9.4	96.0	140.0	11008192	2 x 50		25.6 - 26.8	960.0	1565.0
11008160	2 x 10		14.2 - 15.7	192.0	350.0	11008193	3 G 50		27.2 - 28.5	1440.0	1950.0
11008161	3 G 10		14.9 - 16.5	288.0	435.0	11008194	3 x 50		27.2 - 28.5	1440.0	1950.0
11008162	3 x 10		14.9 - 16.5	288.0	435.0	11008195	4 G 50		29.7 - 31.9	1920.0	2455.0
11008163	4 G 10		16.3 - 17.9	384.0	615.0	11008196	4 x 50		29.7 - 31.9	1920.0	2455.0
11008164	4 x 10		16.3 - 17.9	384.0	615.0	11008197	5 G 50		33.0 - 35.4	2400.0	2970.0
11008165	5 G 10		17.8 - 19.5	480.0	725.0	11008198	5 x 50		33.0 - 35.4	2400.0	2970.0
11008166	5 x 10		17.8 - 19.5	480.0	725.0	11008199	1 x 70		15.5 - 17.1	672.0	715.0
11008167	1 x 16		9.1 - 10.4	153.6	195.0	11008201	3 G 70		31.4 - 33.4	2016.0	2675.0
11008168	2 x 16		16.2 - 17.5	307.2	575.0	11008202	3 x 70		31.4 - 33.4	2016.0	2675.0
11008169	3 G 16		17.2 - 18.4	460.8	700.0	11008203	4 G 70		35.2 - 37.5	2688.0	3340.0
11008170	3 x 16		17.2 - 18.4	460.8	700.0	11008204	4 x 70		35.2 - 37.5	2688.0	3340.0
11008171	4 G 16		19.0 - 20.1	614.4	880.0	11008207	1 x 95		17.1 - 18.7	912.0	925.0
11008172	4 x 16		19.0 - 20.1	614.4	880.0	11008209	3 G 95		35.0 - 37.1	2736.0	3390.0
11008173	5 G 16		20.8 - 22.0	768.0	1060.0	11008210	3 x 95		35.0 - 37.1	2736.0	3390.0
11008174	5 x 16		20.8 - 22.0	768.0	1060.0	11008211	4 G 95		38.8 - 41.1	3648.0	4315.0
11008175	1 x 25		10.9 - 12.0	240.0	285.0	11008212	4 x 95		38.8 - 41.1	3648.0	4315.0
11008176	2 x 25		19.7 - 20.8	480.0	880.0	11008215	1 x 120		19.3 - 20.7	1152.0	1160.0
11008177	3 G 25		20.9 - 22.0	720.0	1075.0	11008219	4 G 120		43.6 - 46.5	4608.0	5465.0
11008178	3 x 25		20.9 - 22.0	720.0	1075.0	11008220	4 x 120		43.6 - 46.5	4608.0	5465.0
11008179	4 G 25		23.0 - 24.0	960.0	1315.0	11008221	1 x 150		21.1 - 22.8	1440.0	1460.0
11008180	4 x 25		23.0 - 24.0	960.0	1315.0	11008225	4 G 150		48.1 - 51.0	5760.0	6830.0
11008181	5 G 25		25.3 - 26.6	1200.0	1590.0	11008226	4 x 150		48.1 - 51.0	5760.0	6830.0
11008182	5 x 25		25.3 - 26.6	1200.0	1590.0	11008227	1 x 185		23.0 - 24.8	1776.0	1780.0
11008183	1 x 35		12.3 - 13.2	336.0	380.0	11008231	4 G 185		53.0 - 57.0	7104.0	8575.0
11008184	2 x 35		22.2 - 23.5	672.0	1130.0	11008232	4 x 185		53.0 - 57.0	7104.0	8575.0
11008185	3 G 35		23.6 - 25.2	1008.0	1405.0	11008233	1 x 240		26.3 - 27.6	2304.0	2300.0
11008186	3 x 35		23.6 - 25.2	1008.0	1405.0	11008237	4 G 240		59.7 - 65.1	9216.0	11085.0
11008187	4 G 35		25.9 - 27.7	1344.0	1745.0	11008238	4 x 240		59.7 - 65.1	9216.0	11085.0
11008188	4 x 35		25.9 - 27.7	1344.0	1745.0	11008239	1 x 300		29.0 - 31.0	2880.0	2910.0
11008189	5 G 35		28.6 - 30.6	1680.0	2100.0						

NSGAFÖU 1,8/3 kV

short-circuit and earth-fault proof up to 1000 V, oil-resistant, for increased mechanical stress



TECHNICAL DATA

Rubber sheathed single core cable acc. to DIN VDE 0250-602

Temperature range	flexible -25°C to +80°C fixed -40°C to +80°C
Permissible operating temperature of the conductor	+90°C
Nominal voltage	AC U_0/U 1800/3000 V
Max. permissible operating voltage	alternating current (AC) conductor/earth 2100 V three-phase alternating current (AC) conductor/conductor 3600 V direct current (DC) conductor/earth 2700 V direct current (DC) conductor/conductor 5400 V
Test voltage	6000 V
Minimum bending radius	flexible 10x Outer-Ø fixed 6x Outer-Ø

- x = without protective conductor
- Outer cladding: rubber (polychloropren) acc. to DIN VDE 0207-21 (compound type 5GM3)
- Colour: see table

PROPERTIES

- resistant to: oil

TESTS

- flame-retardant acc. to DIN VDE 0482-332-1-2 / DIN EN 60332-1-2 / IEC 60332-1-2
- oil-resistant acc. to DIN VDE 0473-811-404 / DIN EN 60811-404 / IEC 60811-404

APPLICATION

For use in rail vehicles and buses, as well as in dry rooms. The cable is short-circuit and earth-fault proof in switchgear and distribution boards up to 1000 V. Normative permissible laying types are: in pipes, closed installation ducts, for connecting moving parts, device wiring and bundled. Not for use on cable ladders and cable trays.

CABLE STRUCTURE

- Copper wire tinned, finely stranded acc. to DIN VDE 0295 Class 5 / IEC 60228 Class 5
- Core insulation: rubber (EPR) acc. to DIN VDE 0207-20 (compound type 3GI3)

NOTES

- the conductor is metrically (mm²) constructed, AWG numbers are approximated, and are for reference only

Colour: black

Part no.	No. cores x cross-sec. mm ²	AWG, approx.	Outer-Ø max. mm	Cu-weight kg/km	Weight kg/km, approx.
38501	1 x 1.5	16	7.0	14.4	62.0
38502	1 x 2.5	14	7.5	24.0	76.0
38503	1 x 4	12	9.0	38.0	95.0
38504	1 x 6	10	9.5	58.0	140.0
38505	1 x 10	8	11.0	96.0	190.0
38506	1 x 16	6	13.0	154.0	270.0
38507	1 x 25	4	15.0	240.0	410.0
38508	1 x 35	2	16.5	336.0	490.0
38509	1 x 50	1	18.0	480.0	650.0
38510	1 x 70	2/0	20.5	672.0	900.0
38511	1 x 95	3/0	24.0	912.0	1200.0
38513	1 x 120	4/0	26.0	1152.0	1450.0
38514	1 x 150	300 kcmil	28.0	1440.0	1800.0
38512	1 x 185	350 kcmil	31.0	1776.0	2200.0
38515	1 x 240	500 kcmil	34.5	2304.0	2650.0
38516	1 x 300	600 kcmil	38.0	2880.0	3250.0

Colour: orange

Part no.	No. cores x cross-sec. mm ²	AWG, approx.	Outer-Ø max. mm	Cu-weight kg/km	Weight kg/km, approx.
17001252	1 x 1.5	16	7.0	14.4	62.0
710665	1 x 2.5	14	7.5	24.0	76.0
710666	1 x 4	12	9.0	38.0	95.0
710223	1 x 6	10	9.5	58.0	140.0
17000914	1 x 10	8	11.0	96.0	190.0
17000915	1 x 16	6	13.0	154.0	270.0
17000916	1 x 25	4	15.0	240.0	410.0
17000917	1 x 35	2	16.5	336.0	490.0
17000918	1 x 50	1	18.0	480.0	650.0
17000919	1 x 70	2/0	20.5	672.0	900.0
17000920	1 x 95	3/0	24.0	912.0	1200.0
17000921	1 x 120	4/0	26.0	1152.0	1450.0
17000922	1 x 150	300 kcmil	28.0	1440.0	1800.0
17000923	1 x 185	350 kcmil	31.0	1776.0	2200.0
17000924	1 x 240	500 kcmil	34.5	2304.0	2650.0
17001253	1 x 300	600 kcmil	38.0	2880.0	3250.0



TECHNICAL DATA

PVC control and connection cable in alignment with DIN VDE 0262, DIN VDE 0285-525-2-51 / DIN EN 50525-2-51

Temperature range	flexible -15°C to +80°C fixed -40°C to +80°C
Nominal voltage	AC U ₀ /U 600/1000 V
Test voltage core/core	4000 V
Breakdown voltage	8000 V
Minimum bending radius	flexible 7,5x Outer-Ø fixed 4x Outer-Ø

■ CABLE STRUCTURE

- Copper wire bare, finely stranded acc. to DIN VDE 0295 class 5 / IEC 60228 class 5
- Core insulation: PVC acc. to DIN VDE 0207-363-3 / DIN EN 50363-3 (compound type T12)
- Core identification acc. to DIN VDE 0293-334, black cores with consecutive labeling in white digits
- Protective conductor: starting with 3 cores, G = with protective conductor GN-YE, in the outer layer, x = without protective conductor (OZ)
- Cores stranded in layers with optimal lay lengths
- Outer sheath: PVC acc. to DIN VDE 0207-363-4-1 / DIN EN 50363-4-1 (compound type TM2)
- Sheath colour: black (RAL 9005)
- Length marking: in metres

■ PROPERTIES

Part no.	No. cores x cross-sec. mm ²	AWG, approx.	Outer Ø mm, approx.	Cu-weight kg/km	Weight kg/km, approx.
10550	2 x 0.5	20	6.2	9.6	56.0
10551	3 G 0.5	20	6.5	14.0	68.0
10552	3 x 0.5	20	6.5	14.0	68.0
10553	4 G 0.5	20	7.0	19.0	100.0
10554	4 x 0.5	20	7.0	19.0	100.0
10555	5 G 0.5	20	7.9	24.0	117.0
10556	5 x 0.5	20	7.9	24.0	117.0
10557	6 G 0.5	20	8.5	29.0	126.0
10558	7 G 0.5	20	8.5	34.0	138.0
10559	7 x 0.5	20	8.5	34.0	138.0
10560	8 G 0.5	20	9.4	38.0	150.0
10561	8 x 0.5	20	9.4	38.0	150.0
10562	10 G 0.5	20	11.0	48.0	176.0
10563	12 G 0.5	20	11.3	58.0	200.0
10564	12 x 0.5	20	11.3	58.0	200.0
10565	14 G 0.5	20	11.9	67.0	230.0
10566	16 G 0.5	20	12.7	76.0	250.0
10567	18 G 0.5	20	13.3	86.0	276.0
10568	20 G 0.5	20	14.2	96.0	293.0
10569	21 G 0.5	20	14.2	96.0	305.0
10570	25 G 0.5	20	15.8	120.0	335.0
10571	30 G 0.5	20	16.9	144.0	348.0
10572	32 G 0.5	20	18.7	154.0	355.0

- resistant to: UV radiation, weathering effects
- largely resistant to: oil, for details, see "Technical Information"
- for outdoor use
- the materials used during manufacturing are cadmium-free, contain no silicone and are free from substances harmful to the wetting properties of lacquers

■ TESTS

- flame-retardant acc. to DIN VDE 0482-332-1-2 / DIN EN 60332-1-2 / IEC 60332-1-2
- UV-resistant acc. to DIN EN ISO 4892-2
- weather-resistant acc. to DIN EN ISO 4892-2

■ APPLICATION

Used as a connection and control cable in machine tools, assembly lines and conveyor belts, production lines, in plant construction, heating and air-conditioning technology, in smelters and steel mills. Suitable for flexible applications involving medium mechanical stress with free movement, without tensile stress and without forced motion control in dry, damp and wet rooms, as well as outdoors (fixed installation). May not be laid directly in soil (suitable for direct burial starting with an outer diameter of 18.0 mm) or water. Primarily used in southern European and Arabic countries, as well as in eastern states.

■ NOTES

- the conductor is metrically (mm²) constructed, AWG numbers are approximated, and are for reference only

Part no.	No. cores x cross-sec. mm ²	AWG, approx.	Outer Ø mm, approx.	Cu-weight kg/km	Weight kg/km, approx.
10573	34 G 0.5	20	19.3	163.0	520.0
10574	40 G 0.5	20	20.0	192.0	590.0
10575	42 G 0.5	20	20.6	202.0	595.0
10576	50 G 0.5	20	22.3	240.0	715.0
10577	52 G 0.5	20	22.3	252.0	740.0
10578	61 G 0.5	20	23.5	293.0	840.0
10579	65 G 0.5	20	24.2	312.0	880.0
10580	80 G 0.5	20	26.7	384.0	960.0
10581	100 G 0.5	20	29.7	480.0	1050.0
10582	2 x 0.75	19	6.7	14.0	66.0
10583	3 G 0.75	19	7.1	22.0	74.0
10584	3 x 0.75	19	7.1	22.0	74.0
10585	4 G 0.75	19	7.7	29.0	126.0
10586	4 x 0.75	19	7.7	29.0	126.0
10587	5 G 0.75	19	8.5	36.0	140.0
10588	5 x 0.75	19	8.5	36.0	140.0
10589	6 G 0.75	19	9.5	43.0	170.0
10590	6 x 0.75	19	9.5	43.0	170.0
10591	7 G 0.75	19	9.5	50.0	190.0
10592	7 x 0.75	19	9.5	50.0	190.0
10593	8 G 0.75	19	10.2	58.0	212.0
10594	8 x 0.75	19	10.2	58.0	212.0
10595	9 G 0.75	19	11.1	65.0	227.0

Part no.	No. cores x cross-sec. mm ²	AWG, approx.	Outer Ø mm, approx.	Cu-weight kg/km	Weight kg/km, approx.
10596	10 G 0.75	19	12.2	72.0	238.0
10597	12 G 0.75	19	12.6	86.0	257.0
10598	12 x 0.75	19	12.6	86.0	257.0
10599	14 G 0.75	19	13.2	101.0	286.0
10600	15 G 0.75	19	14.0	108.0	319.0
10601	18 G 0.75	19	14.8	130.0	362.0
10602	20 G 0.75	19	15.7	144.0	394.0
10603	21 G 0.75	19	15.7	151.0	422.0
10604	25 G 0.75	19	17.5	180.0	486.0
10605	32 G 0.75	19	20.3	230.0	595.0
10606	34 G 0.75	19	21.1	245.0	638.0
10607	37 G 0.75	19	21.1	260.0	696.0
10608	40 G 0.75	19	21.8	288.0	726.0
10609	41 G 0.75	19	22.5	296.0	750.0
10610	42 G 0.75	19	22.5	302.0	770.0
10611	50 G 0.75	19	24.4	360.0	895.0
10612	61 G 0.75	19	25.8	439.0	1070.0
10613	65 G 0.75	19	26.7	468.0	1110.0
10614	80 G 0.75	19	29.7	576.0	1500.0
10615	100 G 0.75	19	33.0	720.0	1889.0
10616	2 x 1	18	7.0	19.2	80.0
10617	3 G 1	18	7.4	29.0	96.0
10618	3 x 1	18	7.4	29.0	96.0
10619	4 G 1	18	8.2	38.0	100.0
10620	4 x 1	18	8.2	38.0	100.0
10621	5 G 1	18	9.0	48.0	130.0
10622	5 x 1	18	9.0	48.0	130.0
10623	6 G 1	18	9.9	58.0	150.0
10624	7 G 1	18	9.9	67.0	170.0
10625	7 x 1	18	9.9	67.0	170.0
10626	8 G 1	18	10.9	77.0	230.0
10627	9 G 1	18	11.7	86.0	250.0
10628	10 G 1	18	12.8	96.0	270.0
10629	10 x 1	18	12.8	96.0	270.0
10630	12 G 1	18	13.2	115.0	290.0
10631	12 x 1	18	13.2	115.0	290.0
10632	14 G 1	18	14.0	134.0	320.0
10633	16 G 1	18	14.8	154.0	360.0
10634	18 G 1	18	15.7	173.0	405.0
10635	18 x 1	18	15.7	173.0	405.0
10636	20 G 1	18	16.7	192.0	450.0
10637	20 x 1	18	16.7	192.0	480.0
10638	21 G 1	18	16.7	205.0	510.0
10639	24 G 1	18	19.6	236.0	550.0
10640	25 G 1	18	19.6	240.0	570.0
10641	25 x 1	18	19.6	240.0	570.0
10642	26 G 1	18	19.6	252.0	590.0
10643	30 x 1	18	20.6	308.0	650.0
10644	34 G 1	18	22.1	326.0	750.0
10645	36 G 1	18	22.1	346.0	790.0
10646	40 G 1	18	22.9	384.0	850.0
10647	40 x 1	18	22.9	384.0	850.0
10648	41 G 1	18	23.7	394.0	890.0
10649	42 G 1	18	23.7	403.0	900.0
10650	50 G 1	18	25.6	480.0	1100.0
10651	56 G 1	18	26.4	538.0	1190.0
10652	61 G 1	18	27.3	586.0	1266.0
10653	65 G 1	18	28.3	628.0	1560.0
10654	80 G 1	18	31.5	786.0	1810.0
10655	100 G 1	18	35.0	960.0	1950.0
10656	2 x 1.5	16	8.2	29.0	95.0
10657	3 G 1.5	16	8.7	43.0	112.0
10658	3 x 1.5	16	8.7	43.0	112.0
10659	4 G 1.5	16	9.7	58.0	139.0
10660	4 x 1.5	16	9.7	58.0	139.0
10661	5 G 1.5	16	10.5	72.0	170.0

Part no.	No. cores x cross-sec. mm ²	AWG, approx.	Outer Ø mm, approx.	Cu-weight kg/km	Weight kg/km, approx.
10662	5 x 1.5	16	10.5	72.0	170.0
10663	6 G 1.5	16	11.6	86.0	190.0
10664	7 G 1.5	16	11.6	101.0	225.0
10665	7 x 1.5	16	11.6	101.0	225.0
10666	8 G 1.5	16	12.7	115.0	250.0
10667	9 G 1.5	16	13.9	130.0	280.0
10668	10 G 1.5	16	15.2	144.0	300.0
10669	11 G 1.5	16	15.2	158.0	330.0
10670	12 G 1.5	16	15.7	173.0	370.0
10671	12 x 1.5	16	15.7	173.0	370.0
10672	14 G 1.5	16	16.6	202.0	400.0
10673	16 G 1.5	16	17.5	230.0	450.0
10674	18 G 1.5	16	19.6	259.0	520.0
10675	19 G 1.5	16	19.6	279.0	550.0
10676	20 G 1.5	16	20.6	288.0	600.0
10677	21 G 1.5	16	20.6	302.0	600.0
10678	25 G 1.5	16	22.6	360.0	730.0
10679	32 G 1.5	16	24.7	461.0	880.0
10680	34 G 1.5	16	25.6	490.0	950.0
10681	40 G 1.5	16	26.8	576.0	990.0
10682	42 G 1.5	16	27.7	605.0	1120.0
10683	50 G 1.5	16	30.4	720.0	1400.0
10684	56 G 1.5	16	31.5	806.0	1530.0
10685	61 G 1.5	16	32.6	878.0	1700.0
10686	65 G 1.5	16	33.5	936.0	1900.0
10687	80 G 1.5	16	37.5	1152.0	2300.0
10688	100 G 1.5	16	41.8	1440.0	2700.0
10689	2 x 2.5	14	9.6	48.0	160.0
10690	3 G 2.5	14	10.1	72.0	175.0
10691	3 x 2.5	14	10.1	72.0	175.0
10692	4 G 2.5	14	11.2	96.0	203.0
10693	4 x 2.5	14	11.2	96.0	203.0
10694	5 G 2.5	14	12.5	120.0	251.0
10695	5 x 2.5	14	12.5	120.0	251.0
10696	7 G 2.5	14	13.8	168.0	330.0
10697	7 x 2.5	14	13.8	168.0	330.0
10698	8 G 2.5	14	15.1	192.0	400.0
10699	12 G 2.5	14	19.6	288.0	553.0
10700	14 G 2.5	14	20.5	336.0	630.0
10701	18 G 2.5	14	22.6	432.0	795.0
10702	21 G 2.5	14	23.8	504.0	930.0
10703	25 G 2.5	14	26.2	600.0	1110.0
10704	34 G 2.5	14	30.4	816.0	1450.0
10705	42 G 2.5	14	33.0	1008.0	1750.0
10706	50 G 2.5	14	36.3	1200.0	2100.0
10707	61 G 2.5	14	38.8	1464.0	2540.0
10708	100 G 2.5	14	50.0	2400.0	3850.0
10709	2 x 4	12	11.0	77.0	180.0
10710	3 G 4	12	11.6	115.0	230.0
10711	4 G 4	12	12.9	154.0	310.0
10712	5 G 4	12	14.3	192.0	410.0
10713	7 G 4	12	15.8	269.0	540.0
10714	8 G 4	12	17.3	307.0	710.0
10715	12 G 4	12	22.1	461.0	860.0
10716	3 G 6	10	13.1	173.0	370.0
10717	4 G 6	10	14.5	230.0	430.0
10718	5 G 6	10	16.2	288.0	650.0
10719	7 G 6	10	19.0	403.0	860.0
10720	3 G 10	8	16.7	288.0	660.0
10721	4 G 10	8	19.5	384.0	790.0
10722	5 G 10	8	21.3	480.0	960.0
10723	7 G 10	8	23.2	672.0	1300.0
10724	3 G 16	6	21.1	461.0	700.0
10725	4 G 16	6	22.9	614.0	1100.0
10726	5 G 16	6	25.2	768.0	1600.0
10727	7 G 16	6	27.6	1075.0	1890.0

JZ-600 / OZ-600



Part no.	No. cores x cross-sec. mm ²	AWG, approx.	Outer Ø mm, approx.	Cu-weight kg/km	Weight kg/km, approx.
10728	3 G 25	4	25.0	720.0	1450.0
10729	4 G 25	4	27.4	960.0	1600.0
10730	5 G 25	4	30.7	1200.0	2050.0
10731	7 G 25	4	34.0	1680.0	2900.0
10732	3 G 35	2	27.5	1008.0	1900.0
10733	4 G 35	2	30.4	1344.0	2400.0
10734	5 G 35	2	34.0	1680.0	2900.0
10735	3 G 50	1	32.2	1440.0	2700.0
10736	4 G 50	1	35.8	1920.0	3400.0
10742	5 G 50	1	39.9	2400.0	4361.0
10737	3 G 70	2/0	36.4	2016.0	3300.0

Part no.	No. cores x cross-sec. mm ²	AWG, approx.	Outer Ø mm, approx.	Cu-weight kg/km	Weight kg/km, approx.
10738	4 G 70	2/0	40.4	2688.0	4400.0
10743	5 G 70	2/0	45.1	3360.0	5807.0
10739	3 G 95	3/0	41.9	2736.0	5050.0
10740	4 G 95	3/0	46.4	3648.0	6010.0
10744	5 G 95	3/0	51.7	4560.0	7752.0
10741	4 G 120	4/0	51.3	4608.0	7500.0
11007924	5 G 120	4/0	56.4	5760.0	7659.0
10745	4 G 150	300 kcmil	57.0	5760.0	8640.0
11007925	5 G 150	300 kcmil	62.9	7200.0	9562.0
10746	4 G 185	350 kcmil	62.8	7104.0	10380.0

JZ-600-Y-CY / OZ-600-Y-CY

EMC-preferred type, with inner sheath



TECHNICAL DATA

PVC control and connection cable in alignment with DIN VDE 0262, DIN VDE 0285-525-2-51 / DIN EN 50525-2-51

Temperature range	flexible -15°C to +80°C fixed -40°C to +80°C
Nominal voltage	AC U ₀ /U 600/1000 V
Test voltage core/core	4000 V
Breakdown voltage	8000 V
Coupling resistance	at 30 MHz, approx. 250 Ohm/km
Minimum bending radius	flexible 10x Outer-Ø fixed 5x Outer-Ø

- largely resistant to: oil, for details, see "Technical Information"
- for outdoor use
- the materials used during manufacturing are cadmium-free, contain no silicone and are free from substances harmful to the wetting properties of lacquers

TESTS

- flame-retardant acc. to DIN VDE 0482-332-1-2 / DIN EN 60332-1-2 / IEC 60332-1-2
- UV-resistant acc. to DIN EN ISO 4892-2
- weather-resistant acc. to DIN EN ISO 4892-2

APPLICATION

Used as a connection and control cable in machine tools, assembly lines and conveyor belts, production lines, plant construction, heating and air-conditioning technology and in smelters and steel mills. Suitable for flexible applications involving medium mechanical stress with free movement, without tensile stress and without forced motion control in dry, damp and wet rooms, as well as outdoors (fixed installation). May not be laid directly in soil (suitable for direct burial starting with an outer diameter of 20 mm) or water. Due to its extended nominal voltage range and good UV resistance, this cable is primarily used in Southern Europe, Arabic, Asian and Eastern countries. Due to the high screening density, interference-free transmission of signals or pulses is ensured. EMC= Electromagnetic Compatibility; in order to optimise EMC properties, we recommend a double-sided and all-round large contact area of the copper braiding.

CABLE STRUCTURE

- Copper wire bare, finely stranded acc. to DIN VDE 0295 class 5 / IEC 60228 class 5
- Core insulation: PVC acc. to DIN VDE 0207-363-3 / DIN EN 50363-3 (compound type T12)
- Core identification acc. to DIN VDE 0293-334, black cores with consecutive labeling in white digits
- Protective conductor: starting with 3 cores, G = with protective conductor GN-YE, in the outer layer, x = without protective conductor (OZ)
- Cores stranded in layers with optimal lay lengths
- Inner sheath: PVC
- Screen: braided screen of tinned copper, approx. coverage 85%
- Outer sheath: PVC acc. to DIN VDE 0207-363-4-1 / DIN EN 50363-4-1 (compound type TM2)
- Sheath colour: black (RAL 9005)
- Length marking: in metres

NOTES

- the conductor is metrically (mm²) constructed, AWG numbers are approximated, and are for reference only

PROPERTIES

- resistant to: UV radiation, weathering effects

Part no.	No. cores x cross-sec. mm ²	AWG, approx.	Outer Ø mm, approx.	Cu-weight kg/km	Weight kg/km, approx.
11464	2 x 0.5	20	8.4	41.0	115.0
11465	3 G 0.5	20	8.8	45.0	127.0
11466	4 G 0.5	20	9.3	54.0	149.0
11467	5 G 0.5	20	10.1	66.0	169.0
11469	7 G 0.5	20	10.9	79.0	230.0
11472	12 G 0.5	20	14.0	137.0	386.0
11475	18 G 0.5	20	16.3	156.0	428.0
11478	25 G 0.5	20	19.0	250.0	693.0
11489	2 x 0.75	19	8.9	46.0	128.0
11490	3 G 0.75	19	9.3	57.0	143.0
11491	4 G 0.75	19	10.1	63.0	164.0
11492	5 G 0.75	19	11.0	76.0	198.0
11494	7 G 0.75	19	11.9	100.0	232.0
11498	12 G 0.75	19	15.4	175.0	360.0
11501	18 G 0.75	19	18.0	240.0	562.0
11504	25 G 0.75	19	21.9	306.0	729.0
11516	2 x 1	18	9.2	54.0	146.0
11517	3 G 1	18	9.8	64.0	165.0

Part no.	No. cores x cross-sec. mm ²	AWG, approx.	Outer Ø mm, approx.	Cu-weight kg/km	Weight kg/km, approx.
11518	4 G 1	18	10.4	76.0	204.0
11519	5 G 1	18	11.6	89.0	224.0
11521	7 G 1	18	12.3	114.0	379.0
11525	12 G 1	18	16.2	186.0	430.0
11528	18 G 1	18	18.9	284.0	636.0
11532	25 G 1	18	22.8	387.0	837.0
11546	2 x 1.5	16	10.4	64.0	175.0
11547	3 G 1.5	16	11.3	82.0	213.0
11548	4 G 1.5	16	12.0	99.0	247.0
11549	5 G 1.5	16	13.1	123.0	300.0
11551	7 G 1.5	16	14.6	148.0	364.0
11556	12 G 1.5	16	18.7	274.0	668.0
11559	18 G 1.5	16	22.8	386.0	844.0
11563	25 G 1.5	16	26.2	531.0	1356.0
11574	2 x 2.5	14	12.0	110.0	241.0
11575	3 G 2.5	14	12.6	148.0	266.0
11576	4 G 2.5	14	13.9	169.0	351.0
11577	5 G 2.5	14	15.4	220.0	434.0

JZ-600-Y-CY / OZ-600-Y-CY

EMC-preferred type, with inner sheath



Part no.	No. cores x cross-sec. mm ²	AWG, approx.	Outer Ø mm, approx.	Cu-weight kg/km	Weight kg/km, approx.
11578	7 G 2.5	14	16.6	284.0	517.0
11580	12 G 2.5	14	22.8	470.0	862.0
11582	18 G 2.5	14	26.2	572.0	1236.0
11584	25 G 2.5	14	30.6	740.0	1659.0
11590	2 x 4	12	13.4	124.0	306.0
11591	3 G 4	12	14.7	178.0	444.0
11592	4 G 4	12	15.9	234.0	489.0
11593	5 G 4	12	17.6	284.0	623.0
11594	7 G 4	12	19.0	385.0	775.0
11596	12 G 4	12	25.5	581.0	1244.0
11597	2 x 6	10	15.2	176.0	433.0
11598	3 G 6	10	16.2	245.0	572.0
11599	4 G 6	10	17.8	316.0	673.0
11600	5 G 6	10	19.4	442.0	841.0
11601	7 G 6	10	22.2	530.0	1078.0
11602	2 x 10	8	18.6	260.0	640.0
11603	3 G 10	8	20.0	367.0	820.0
11604	4 G 10	8	22.7	549.0	979.0
11605	5 G 10	8	24.8	604.0	1207.0
11606	7 G 10	8	26.8	820.0	2210.0
11607	2 x 16	6	23.2	491.0	1150.0
11608	3 G 16	6	24.5	653.0	1395.0
11609	4 G 16	6	26.5	807.0	1426.0

Part no.	No. cores x cross-sec. mm ²	AWG, approx.	Outer Ø mm, approx.	Cu-weight kg/km	Weight kg/km, approx.
11610	5 G 16	6	29.3	940.0	2720.0
11611	7 G 16	6	32.0	1345.0	3213.0
11612	3 G 25	4	29.0	920.0	1810.0
11613	4 G 25	4	32.0	1169.0	2261.0
11614	5 G 25	4	35.3	1420.0	2773.0
11615	7 G 25	4	38.6	1921.0	4980.0
11616	3 G 35	2	31.9	1250.0	2400.0
11617	4 G 35	2	35.0	1680.0	2973.0
11618	5 G 35	2	38.6	2020.0	3548.0
11619	3 G 50	1	37.0	1887.0	3120.0
11620	4 G 50	1	40.8	2370.0	3873.0
11621	5 G 50	1	45.2	2880.0	4634.0
11622	3 G 70	2/0	41.5	2516.0	4220.0
11623	4 G 70	2/0	45.9	3257.0	5546.0
11624	5 G 70	2/0	50.8	4032.0	6410.0
11625	3 G 95	3/0	47.4	3086.0	5240.0
11626	4 G 95	3/0	52.3	4060.0	6538.0
11627	5 G 95	3/0	57.4	5244.0	7812.0
11628	3 G 120	4/0	52.2	4176.0	7210.0
11629	4 G 120	4/0	56.9	5231.0	7994.0
13137	4 G 150	300 kcmil	63.3	7760.0	10305.0
13147	4 G 185	350 kcmil	69.4	8104.0	12154.0

HELUTHERM® 145

temperature-resistant, cross-linked, improved behaviour in case of fire



TECHNICAL DATA

Single core

Temperature range	flexible -35°C to +120°C fixed -55°C to +145°C
Nominal voltage	0.25 - 1 mm²: AC U ₀ /U 300/500 V 1.5 - 240 mm²: AC U ₀ /U 450/750 V 1.5 - 240 mm²: fixed and protected installation AC U ₀ /U 600/1000 V
Test voltage	3500 V
Minimum bending radius	flexible 8x Outer-Ø fixed 4x Outer-Ø

CABLE STRUCTURE

- Copper wire tinned, finely stranded acc. to DIN VDE 0295 Class 5 / IEC 60228 Class 5
- Core insulation: cross-linked polyolefin
- Core identification: see table

PROPERTIES

- resistant to: oil, UV radiation, ozone, weathering effects
- abrasion-resistant, notch-resistant
- for outdoor use
- halogen-free
- the materials used during manufacturing are cadmium-free, contain no silicone and are free from substances harmful to the wetting properties of lacquers
- no fire propagation

TESTS

- halogen-free acc. to DIN VDE 0482-754-1 / DIN EN 60754-1 / IEC 60754-1
- corrosiveness of combustion gases acc. to DIN VDE 0482-754-2 / DIN EN 60754-2 / IEC 60754-2
- flame-retardant acc. to DIN VDE 0482-332-1-2 / DIN EN 60332-1-2 / IEC 60332-1-2
- bundle fire test acc. to DIN VDE 0482-332-3-22 / DIN EN 60332-3-22 / IEC 60332-3-22
- smoke density acc. to DIN VDE 0482-1034-1+2 / DIN EN 61034-1+2 / IEC 61034-1+2
- protection against fire acc. to DIN EN 45545-2
- oil-resistant acc. to DIN VDE 0473-811-404 / DIN EN 60811-404 / IEC 60811-404, IRM 902 4h at +70°C
- Certifications:
0.5 - 240 mm²: DNV GL

APPLICATION

Temperature resistant single core for the internal wiring of lighting fixtures, heaters, electrical machinery, switching systems and distributors in industrial equipment as well as plant and machinery construction; suitable for laying in tubes on and under plaster, in closed installation ducts, as well as for traffic systems and outdoor applications. Not suitable for direct laying in cable ladders and cable trays, except as a potential equalization cable.

NOTES

- the conductor is metrically (mm²) constructed, AWG numbers are approximated, and are for reference only

Cross-sec. mm²	AWG, approx.	Outer Ø mm, approx.	Cu-weight kg/km	Weight kg/km, approx.	black (RAL 9005)	green-yellow	blue (RAL 5015)	brown (RAL 8003)	red (RAL 3000)	white (RAL 9010)	grey (RAL 7001)	purple (RAL 4005)
					Part no.	Part no.	Part no.	Part no.	Part no.	Part no.	Part no.	
0.25	24	1.6	2.4	4.0	50999	50998	51070	51071	51072	51073	51074	51075
0.34	22	1.7	3.2	5.0	51167	51166	51168	51169	51170	51171	51172	51173
0.5	20	1.9	4.8	7.0	51281	51280	51282	51283	51284	51285	51286	51287
0.75	19	2.2	7.2	11.0	51295	51294	51296	51297	51298	51299	51300	51301
1	18	2.5	9.6	14.0	51309	51308	51310	51311	51312	51313	51314	51315
1.5	16	2.9	14.4	20.0	51323	51322	51324	51325	51326	51327	51328	51329
2.5	14	3.5	24.0	30.0	51337	51336	51338	51339	51340	51341	51342	51343
4	12	4.3	38.0	47.0	51351	51350	51352	51353	51354	51355	51356	51357
6	10	5.0	58.0	72.0	51365	51364	51366	51367	51368	51369	51370	51371
10	8	6.3	96.0	120.0	51379	51378	51380	51381	51382	51383	51384	51385
16	6	7.3	154.0	182.0	51420	51419	51421	51422	51423	51424	51425	51426
25	4	9.6	240.0	272.0	51434	51433	51435	51436	51437	51438	51439	51440
35	2	10.8	336.0	371.0	51448	51447	51449	51450	51451	51452	51453	51454
50	1	12.6	480.0	530.0	51462	51461	51463	51464	51465	51466	51467	51468
70	2/0	14.6	672.0	730.0	51476	51475	51477	51478	51479	51480	51481	51482
95	3/0	16.5	912.0	964.0	51490	51489	51491	51492	51493	51494	51495	51496
120	4/0	18.0	1152.0	1235.0	51504	51503	51505	51506	51507	51508	51509	51510

HELUTHERM® 145

temperature-resistant, cross-linked, improved behaviour in case of fire



Cross-sec. mm ²	AWG, approx.	Outer Ø mm, approx.	Cu-weight kg/km	Weight kg/km, approx.	black (RAL 9005)	green-yellow	blue (RAL 5015)	brown (RAL 8003)	red (RAL 3000)	white (RAL 9010)	grey (RAL 7001)	purple (RAL 4005)
					Part no.	Part no.	Part no.	Part no.	Part no.	Part no.	Part no.	
150	300 kcmil	20.0	1440.0	1523.0	51518	51517	51519	51520	51521	51522	51523	51524
185	350 kcmil	22.2	1776.0	1850.0	51532	51531	51533	51534	51535	51536	51537	51538
240	500 kcmil	24.5	2304.0	2432.0	51546	51545	51547	51548	51549	51550	51551	51552

Cross-sec. mm ²	AWG, approx.	Outer Ø mm, approx.	Cu-weight kg/km	Weight kg/km, approx.	yellow (RAL 1021)	orange (RAL 2003)	green (RAL 6018)	dark blue (RAL 5010)	beige (RAL 1001)
					Part no.	Part no.	Part no.	Part no.	Part no.
0.25	24	1.6	2.4	4.0	51076	51077	51078	51079	51164
0.34	22	1.7	3.2	5.0	51174	51175	51176	51177	51178
0.5	20	1.9	4.8	7.0	51288	51289	51290	51291	51292
0.75	19	2.2	7.2	11.0	51302	51303	51304	51305	51306
1	18	2.5	9.6	14.0	51316	51317	51318	51319	51320
1.5	16	2.9	14.4	20.0	51330	51331	51332	51333	51334
2.5	14	3.5	24.0	30.0	51344	51345	51346	51347	51348
4	12	4.3	38.0	47.0	51358	51359	51360	51361	51362
6	10	5.0	58.0	72.0	51372	51373	51374	51375	51376
10	8	6.3	96.0	120.0	51386	51387	51388	51389	51390
16	6	7.3	154.0	182.0	51427	51428	51429	51430	51431
25	4	9.6	240.0	272.0	51441	51442	51443	51444	51445
35	2	10.8	336.0	371.0	51455	51456	51457	51458	51459
50	1	12.6	480.0	530.0	51469	51470	51471	51472	51473
70	2/0	14.6	672.0	730.0	51483	51484	51485	51486	51487
95	3/0	16.5	912.0	964.0	51497	51498	51499	51500	51501
120	4/0	18.0	1152.0	1235.0	51511	51512	51513	51514	51515
150	300 kcmil	20.0	1440.0	1523.0	51525	51526	51527	51528	51529
185	350 kcmil	22.2	1776.0	1850.0	51539	51540	51541	51542	51543
240	500 kcmil	24.5	2304.0	2432.0	51553	51554	51555	51556	51557

HELUTHERM® 145 UL/CSA 600V

temperature-resistant, cross-linked



TECHNICAL DATA

Single core acc. to UL-Std. 758 (AWM) Style 3578, CSA-Std. C22.2 No. 210 - AWM I/II A/B

Temperature range	flexible -35°C to +120°C fixed -55°C to +145°C UL (AWM) flexible -35°C to +105°C UL (AWM) fixed -55°C to +105°C
Nominal voltage	UL (AWM) AC 600 V
Test voltage	3000 V
Minimum bending radius	flexible 12.5x Outer-Ø fixed 4x Outer-Ø

- no fire propagation

TESTS

- halogen-free acc. to DIN VDE 0482-754-1 / DIN EN 60754-1 / IEC 60754-1
- corrosiveness of combustion gases acc. to DIN VDE 0482-754-2 / DIN EN 60754-2 / IEC 60754-2
- flame-retardant acc. to CSA FT1
- bundle fire test acc. to DIN VDE 0482-332-3-24 / DIN EN 60332-3-24 / IEC 60332-3-24
- smoke density acc. to DIN VDE 0482-1034-1+2 / DIN EN 61034-1+2 / IEC 61034-1+2
- Certifications:
0.5 - 50 mm²: DNV GL

CABLE STRUCTURE

- Copper wire tinned, finely stranded acc. to DIN VDE 0295 Class 5 / IEC 60228 Class 5
- Core insulation: cross-linked polyolefin
- Core identification: see table

APPLICATION

Temperature resistant single core for the internal wiring of lighting fixtures, heaters, electrical machinery, switching systems and distributors in industrial equipment as well as plant and machinery construction; suitable for laying in tubes, on and under plaster as well as closed installation ducts. Not suitable for direct laying in cable ladders and cable trays.

PROPERTIES

- resistant to: UV radiation, ozone, weathering effects
- abrasion-resistant, notch-resistant
- halogen-free
- the materials used during manufacturing are cadmium-free, contain no silicone and are free from substances harmful to the wetting properties of lacquers

NOTES

- the conductor is metrically (mm²) constructed, AWG numbers are approximated, and are for reference only

Cross-sec. mm ²	AWG, approx.	Outer Ø mm, approx.	Cu-weight kg/km	Weight kg/km, approx.	black (RAL 9005)	green-yellow	blue (RAL 5015)	brown (RAL 8003)	red (RAL 3000)	white (RAL 9010)	grey (RAL 7001)	purple (RAL 4005)
					Part no.	Part no.	Part no.	Part no.	Part no.	Part no.	Part no.	
0.25	24	2.3	2.4	7.0	59473	59472	59474	59475	59476	59477	59478	59479
0.5	20	2.6	4.8	11.0	59487	59486	59488	59489	59490	59491	59492	59493
0.75	19	2.8	7.2	14.0	59501	59500	59502	59503	59504	59505	59506	59507
1	18	2.9	9.6	17.0	59515	59514	59516	59517	59518	59519	59520	59521
1.5	16	3.1	14.4	22.0	59529	59528	59530	59531	59532	59533	59534	59535
2.5	14	3.6	24.0	33.0	59543	59542	59544	59545	59546	59547	59548	59549
4	12	4.3	38.4	53.0	59557	59556	59558	59559	59560	59561	59562	59563
6	10	5.0	57.6	78.0	59571	59570	59572	59573	59574	59575	59576	59577
10	8	6.4	96.0	136.0	59585	59584	59586	59587	59588	59589	59590	59591
16	6	7.5	154.0	203.0	59599	59598	59600	59601	59602	59603	59604	59605
25	4	9.6	240.0	300.0	59613	59612	59614	59615	59616	59617	59618	59619
35	2	10.8	336.0	405.0	59627	59626	59628	59629	59630	59631	59632	59633
50	1	12.6	480.0	580.0	59641	59640	59642	59643	59644	59645	59646	59647

HELUTHERM® 145 UL/CSA 600V

temperature-resistant, cross-linked



Cross-sec. mm ²	AWG, approx.	Outer Ø mm, approx.	Cu-weight kg/km	Weight kg/km, approx.	yellow	orange	green	pink	beige
					(RAL 1021) Part no.	(RAL 2003) Part no.	(RAL 6018) Part no.	(RAL 3015) Part no.	(RAL 1001) Part no.
0.25	24	2.3	2.4	7.0	59480	59481	59482	59483	59484
0.5	20	2.6	4.8	11.0	59494	59495	59496	59497	59498
0.75	19	2.8	7.2	14.0	59508	59509	59510	59511	59512
1	18	2.9	9.6	17.0	59522	59523	59524	59525	59526
1.5	16	3.1	14.4	22.0	59536	59537	59538	59539	59540
2.5	14	3.6	24.0	33.0	59550	59551	59552	59553	59554
4	12	4.3	38.4	53.0	59564	59565	59566	59567	59568
6	10	5.0	57.6	78.0	59578	59579	59580	59581	59582
10	8	6.4	96.0	136.0	59592	59593	59594	59595	59596
16	6	7.5	154.0	203.0	59606	59607	59608	59609	59610
25	4	9.6	240.0	300.0	59620	59621	59622	59623	59624
35	2	10.8	336.0	405.0	59634	59635	59636	59637	59638
50	1	12.6	480.0	580.0	59648	59649	59650	59651	59652



HELUPOWER® THERMFLEX® 145-Single

conductor stranded with optimal lay lengths, reinforced insulation, temperature-resistant, improved behaviour in case of fire

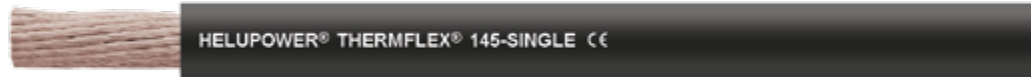

TECHNICAL DATA

Single core

Temperature range	flexible -40°C to +120°C fixed -55°C to +145°C
Short circuit temperature at the conductor	+250°C
Nominal voltage	AC U ₀ /U 600/1000 V
Max. permissible operating voltage	alternating current (AC) conductor/earth 700 V three-phase alternating current (AC) conductor/conductor 1200 V direct current (DC) conductor/earth 900 V direct current (DC) conductor/conductor 1800 V
Test voltage	4000 V
Minimum bending radius	flexible 12.5x Outer-Ø fixed 4x Outer-Ø

- reduced fire propagation, no release of corrosive and toxic gases, low smoke development

TESTS

- halogen-free acc. to DIN VDE 0482-754-1 / DIN EN 60754-1 / IEC 60754-1
- corrosiveness of combustion gases acc. to DIN VDE 0482-754-2 / DIN EN 60754-2 / IEC 60754-2
- bundle fire test acc. to DIN VDE 0482-332-3-22 / DIN EN 60332-3-22 / IEC 60332-3-22
- smoke density acc. to DIN VDE 0482-1034-1+2 / DIN EN 61034-1+2 / IEC 61034-1+2
- oil-resistant acc. to DIN VDE 0473-811-404 / DIN EN 60811-404 / IEC 60811-404, IRM 902 4h at +70°C
- Certifications:
6 - 240 mm²: DNV GL

APPLICATION

This cable is used as a generator connection cable in wind power plants and wherever a high current carrying capacity is required and a reduced outer diameter is beneficial due to limited installation space. Other areas of application: connection cable of thermal class B (130°C) for motors, transformers, relays, coils, magnets; power unit connections in the automotive industry; halogen-free wiring of switch and control cabinets; connecting cable for heating devices; supply cable for high-performance luminaires in industrial areas, sports facilities and traffic infrastructure; wiring of charging stations and pantographs within e-Mobility applications.

CABLE STRUCTURE

- Copper wire tinned, finely stranded acc. to DIN VDE 0295 Class 5 / IEC 60228 Class 5
- Core insulation: cross-linked polyolefin
- Core identification: black
- x = without protective conductor

PROPERTIES

- resistant to: oil, UV radiation, ozone, weathering effects
- abrasion-resistant, notch-resistant
- halogen-free
- the materials used during manufacturing are cadmium-free, contain no silicone and are free from substances harmful to the wetting properties of lacquers

NOTES

- the conductor is metrically (mm²) constructed, AWG numbers are approximated, and are for reference only

Part no.	No. cores x cross-sec. mm ²	AWG, approx.	Outer Ø mm, approx.	Cu-weight kg/km	Weight kg/km, approx.
75486	1 x 6	10	5.4	58.0	79.0
75487	1 x 10	8	6.8	96.0	156.0
75488	1 x 16	6	8.5	154.0	218.0
75489	1 x 25	4	10.3	240.0	331.0
75490	1 x 35	2	11.8	336.0	448.0
75491	1 x 50	1	13.9	480.0	632.0
75492	1 x 70	2/0	16.0	672.0	820.0

Part no.	No. cores x cross-sec. mm ²	AWG, approx.	Outer Ø mm, approx.	Cu-weight kg/km	Weight kg/km, approx.
75493	1 x 95	3/0	17.3	912.0	1076.0
75494	1 x 120	4/0	20.0	1152.0	1392.0
75495	1 x 150	250 kcmil	22.1	1440.0	1788.0
71437	1 x 185	350 kcmil	24.8	1776.0	2106.3
75496	1 x 240	400 kcmil	27.7	2304.0	2749.0
706557	1 x 300	500 kcmil	30.0	2880.0	3910.0
706558	1 x 400	750 kcmil	38.7	3840.0	4870.0



more information on page 78

HELUPOWER® THERMFLEX® 145

conductor stranded with optimal lay lengths, temperature-resistant, improved behaviour in case of fire



TECHNICAL DATA

Sheathed single core cable

Temperature range	flexible -40°C to +120°C fixed -55°C to +145°C
Short circuit temperature at the conductor	+250°C
Nominal voltage	AC U ₀ /U 600/1000 V
Max. permissible operating voltage	alternating current (AC) conductor/earth 700 V three-phase alternating current (AC) conductor/conductor 1200 V direct current (DC) conductor/earth 900 V direct current (DC) conductor/conductor 1800 V
Test voltage	4000 V
Minimum bending radius	flexible 12.5x Outer-Ø fixed 4x Outer-Ø

- the materials used during manufacturing are cadmium-free, contain no silicone and are free from substances harmful to the wetting properties of lacquers
- reduced fire propagation, no release of corrosive and toxic gases, low smoke development

TESTS

- halogen-free acc. to DIN VDE 0482-754-1 / DIN EN 60754-1 / IEC 60754-1
- corrosiveness of combustion gases acc. to DIN VDE 0482-754-2 / DIN EN 60754-2
- bundle fire test acc. to DIN VDE 0482-332-3-22 / DIN EN 60332-3-22 / IEC 60332-3-22
- smoke density acc. to DIN VDE 0482-1034-1+2 / DIN EN 61034-1+2 / IEC 61034-1+2
- oil-resistant acc. to DIN VDE 0473-811-404 / DIN EN 60811-404 / IEC 60811-404, IRM 902 4h at +70°C
- Certifications:
50 - 240 mm²: DNV GL

APPLICATION

This cable is used as a generator connection cable in wind power plants and wherever a high current carrying capacity is required and a reduced outer diameter is beneficial due to limited installation space. Other areas of application: connection cable of thermal class B (130°C) for motors, transformers, relays, coils, magnets; power unit connections in the automotive industry; halogen-free wiring of switch and control cabinets; connecting cable for heating devices; supply cable for high-performance luminaires in industrial areas, sports facilities and traffic infrastructure; wiring of charging stations and pantographs within e-Mobility applications.

CABLE STRUCTURE

- Copper wire tinned, finely stranded acc. to DIN VDE 0295 Class 5 / IEC 60228 Class 5
- Core insulation: cross-linked polyolefin
- Core identification: black
- x = without protective conductor
- Outer sheath: cross-linked polyolefin
- Sheath colour: black

PROPERTIES

- resistant to: oil, UV radiation, ozone, weathering effects
- abrasion-resistant, notch-resistant
- for outdoor use
- halogen-free

NOTES

- the conductor is metrically (mm²) constructed, AWG numbers are approximated, and are for reference only

Part no.	No. cores x cross-sec. mm ²	AWG, approx.	Outer Ø mm, approx.	Cu-weight kg/km	Weight kg/km, approx.
17001667	1 x 50	1	16.0	480.0	711.0
17001668	1 x 70	2/0	18.5	672.0	902.0
17001669	1 x 95	3/0	20.0	912.0	1028.0
17001670	1 x 120	4/0	21.0	1152.0	1515.0
17001671	1 x 150	250 kcmil	25.0	1440.0	1913.0

Part no.	No. cores x cross-sec. mm ²	AWG, approx.	Outer Ø mm, approx.	Cu-weight kg/km	Weight kg/km, approx.
17001672	1 x 185	350 kcmil	28.5	1776.0	2243.0
17001673	1 x 240	400 kcmil	32.5	2304.0	2912.0
17001674	1 x 300	500 kcmil	35.0	2880.0	4089.0
17001675	1 x 400	750 kcmil	42.5	3840.0	5067.0

HELUPOWER® THERMFLEX® 145-C

conductor stranded with optimal lay lengths, temperature-resistant, improved behaviour in case of fire, EMC-preferred type



TECHNICAL DATA

Sheathed single core cable

Temperature range	flexible -40°C to +120°C fixed -55°C to +145°C
Short circuit temperature at the conductor	+250°C
Nominal voltage	AC U ₀ /U 600/1000 V
Max. permissible operating voltage	alternating current (AC) conductor/earth 700 V three-phase alternating current (AC) conductor/conductor 1200 V direct current (DC) conductor/earth 900 V direct current (DC) conductor/conductor 1800 V
Test voltage	4000 V
Minimum bending radius	flexible 12.5x Outer-Ø fixed 4x Outer-Ø

■ CABLE STRUCTURE

- Copper wire tinned, finely stranded acc. to DIN VDE 0295 Class 5 / IEC 60228 Class 5
- Core insulation: cross-linked polyolefin
- Core identification: black
- x = without protective conductor
- Screen: braided screen of tinned copper wires, approx. coverage 85%
- Outer sheath: cross-linked polyolefin
- Sheath colour: black

■ PROPERTIES

- resistant to: oil, UV radiation, ozone, weathering effects
- abrasion-resistant, notch-resistant

Part no.	No. cores x cross-sec. mm ²	AWG, approx.	Outer Ø mm, approx.	Cu-weight kg/km	Weight kg/km, approx.
17001676	1 x 16	6	10.3	183.0	328.0
17001677	1 x 25	4	12.8	275.0	443.0
17001678	1 x 35	2	13.9	391.0	612.0
17001679	1 x 50	1	16.6	532.0	749.0
17001680	1 x 70	2/0	19.1	756.0	968.0
17001681	1 x 95	3/0	20.6	1030.0	1087.0

- for outdoor use
- halogen-free
- the materials used during manufacturing are cadmium-free, contain no silicone and are free from substances harmful to the wetting properties of lacquers
- reduced fire propagation, no release of corrosive and toxic gases, low smoke development

■ TESTS

- halogen-free acc. to DIN VDE 0482-754-1 / DIN EN 60754-1 / IEC 60754-1
- corrosiveness of combustion gases acc. to DIN VDE 0482-754-2 / DIN EN 60754-2 / IEC 60754-2
- bundle fire test acc. to DIN VDE 0482-332-3-22 / DIN EN 60332-3-22 / IEC 60332-3-22
- smoke density acc. to DIN VDE 0482-1034-1+2 / DIN EN 61034-1+2 / IEC 61034-1+2
- oil-resistant acc. to DIN VDE 0473-811-404 / DIN EN 60811-404 / IEC 60811-404, IRM 902 4h at +70°C

■ APPLICATION

This cable is used as a generator connection cable in wind power plants and wherever a high current carrying capacity is required and a reduced outer diameter is beneficial due to limited installation space. Other areas of application: connection cable of thermal class B (130°C) for motors, transformers, relays, coils, magnets; power unit connections in the automotive industry; halogen-free wiring of switch and control cabinets; connecting cable for heating devices; supply cable for high-performance luminaires in industrial areas, sports facilities and traffic infrastructure; wiring of charging stations and pantographs within e-Mobility applications. EMC= Electromagnetic compatibility; to optimize the EMC features we recommend a large round contact of the copper braiding on both ends.

■ NOTES

- the conductor is metrically (mm²) constructed, AWG numbers are approximated, and are for reference only

Part no.	No. cores x cross-sec. mm ²	AWG, approx.	Outer Ø mm, approx.	Cu-weight kg/km	Weight kg/km, approx.
17001682	1 x 120	4/0	23.0	1289.0	1595.0
17001683	1 x 150	250 kcmil	25.6	1568.0	2033.0
17001684	1 x 185	350 kcmil	29.1	1941.0	2363.0
17001685	1 x 240	400 kcmil	33.1	2568.0	3099.0
17001686	1 x 300	500 kcmil	35.6	3147.0	4221.0

HELUWIND® WK POWERLINE ALU 0,6/1 kV

finely stranded Al wire, extremely flexible

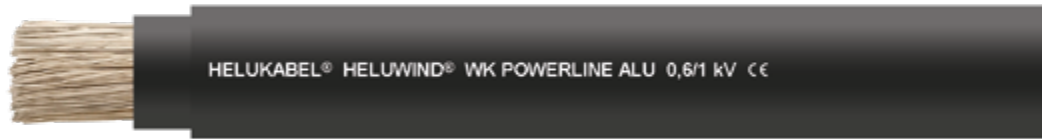

TECHNICAL DATA

Sheathed single core cable in alignment with DIN VDE 0250-813

Temperature range flexible -20°C to +90°C
fixed -40°C to +90°C

Permissible operating temperature of the conductor +90°C

Nominal voltage AC U₀/U 600/1000 V

Test voltage core/core 4000 V

Minimum bending radius flexible 10x Outer-Ø
fixed 4x Outer-Ø

■ CABLE STRUCTURE

- Al wire, finely stranded
- Core insulation: Special-PVC
- Core identification: black
- x = without protective conductor
- Outer sheath: Special-PVC
- Sheath colour: black

■ PROPERTIES

- resistant to: oil, UV radiation

- excellent flexibility enables fast laying
- recyclable

■ TESTS

- flame-retardant acc. to DIN VDE 0482-332-1-2 / DIN EN 60332-1-2 / IEC 60332-1-2

■ APPLICATION

Extremely flexible aluminium cable for use in many areas of energy and plant engineering. The high flexibility and low dead weight can significantly reduce labour time required for installation in the field. The HELUWIND® WK POWERLINE ALU may only be handled using the certified HELUKABEL® C8 crimping method according to IEC 61238-1 Class A. The appropriate tools for this connection method are available for delivery (may also be rented).

■ NOTES

- the conductor is metrically (mm²) constructed, AWG numbers are approximated, and are for reference only
- Further details, as well as information regarding custom solutions and suitable connection technology, can be found at wind@helukabel.de

Part no.	No. cores x cross-sec. mm ²	AWG, approx.	Outer Ø mm, approx.	Al-weight kg/km	Weight kg/km, approx.
707062	1 x 70	2/0	16.5	206.0	379.0
707063	1 x 95	3/0	17.9	280.0	480.0
707064	1 x 120	4/0	19.7	355.0	576.0
706408	1 x 150	250 kcmil	21.7	441.0	743.0

Part no.	No. cores x cross-sec. mm ²	AWG, approx.	Outer Ø mm, approx.	Al-weight kg/km	Weight kg/km, approx.
706088	1 x 185	350 kcmil	24.3	544.0	950.0
706089	1 x 240	400 kcmil	28.1	706.0	1150.0
706084	1 x 300	500 kcmil	31.4	882.0	1400.0
706085	1 x 400	750 kcmil	35.0	1176.0	1692.0

Selection Table WK Powerline ALU

	Approval	FT1/ IEC 60332-1-2	Nominal voltage acc. to UL	Nominal voltage U ₀ /U	halogen-free	extensively oil-resistant	UV-resistant	Temp. fixed installation in °C	Temp. flexing in °C	Cu-screen
Power cable aluminium 0,6/1kV										
WK POWERLINE ALU1	CE	x		0,6/1kV		x	x	-40 to +90 ³	-20 to +90	
WK POWERLINE ALU robust ¹	CE	x		0,6/1kV		x	x	-40 to +90 ³	-20 to +90	
WK POWERLINE ALU torsion	CE	x	1000 V	0,6/1kV		x	x	-40 to +90 ³	-20 to +90	
Power cable aluminium 1,8/3kV										
WK POWERLINE ALU1		x		1,8/3kV		x	x	-40 to +90 ³	-20 to +90	
WK POWERLINE ALU robust ¹		x		1,8/3kV		x	x	-40 to +90 ³	-20 to +90	
WK POWERLINE ALU halogen-free ¹		x		1,8/3kV	x	x	x	-40 to +90 ³	-20 to +90	
Infrastructure cables/medium voltage										
WK POWERLINE ALU MS Single				6-30kV		x	x	-40 to +90 ³	-20 to +90	x
Control cables										
WK POWERLINE ALU MULTI	CE	x		0,6/1kV		x	x	-40 to +90 ³	-20 to +90	
Single cores										
WK POWERLINE ALU SINGLE	CE	x		0,6/1kV		x	x	-40 to +90 ³	-20 to +90	

x¹ for multicore types

* in progress

** in reference to UL 1277

¹ If laid in the ground or foundation only in the protective pipe (watertight)







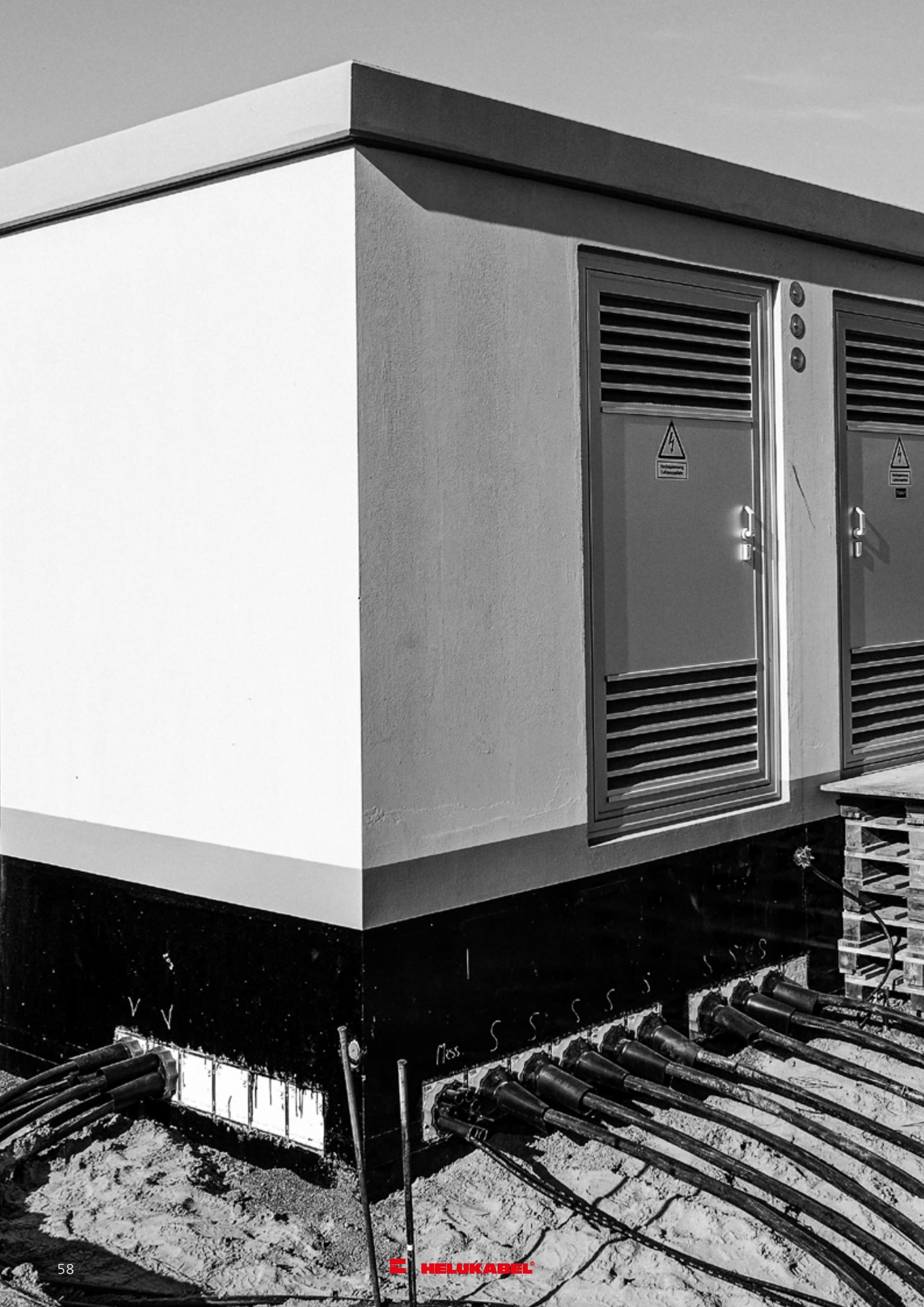

³ max. 3.000 h



more information
on page 78



Selection List Earth & Power Distribution Cables

Description	Properties	Approvals
NY Y	Underground cable 0.6/1 kV, VDE approved	ERC 
NY CY	Underground cable 0.6/1 kV, with concentric conductor, VDE approved	ERC 
NY CWY	Underground cable 0.6/1 kV, with concentric conductor, VDE approved	ERC 
NA Y Y	Underground cable 0.6/1 kV, VDE approved	ERC 
NA Y 2 Y	Underground cable 0.6/1 kV, with PE outer sheath	
NA Y CWY	Underground cable 0.6/1 kV, with concentric conductor, VDE approved	ERC 
N 2 XY	Underground cable 0.6/1 kV, VDE approved, increased current load	
N 2 XCY	Underground cable 0.6/1 kV, with concentric conductor, VDE approved, increased current load	
NA 2 XY	Underground cable 0.6/1 kV, VDE approved, increased current load	



**more information
on page 78**

LAN Cable Outdoor

Category 7e

HELUKAT® 600A
S/FTP PVC/PVC

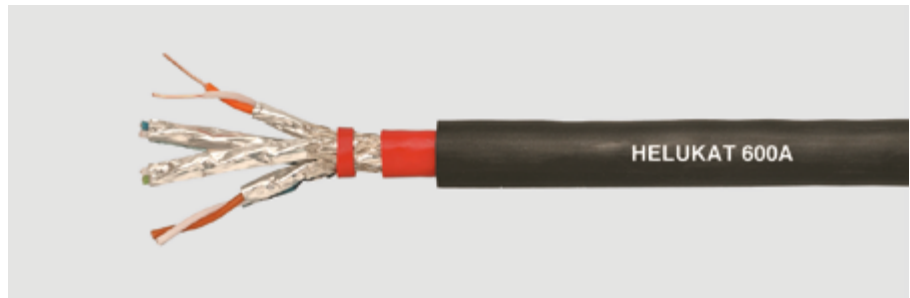

Cable structure

Inner conductor Ø:	0,58 mm
Conductor material:	Copper, bare
Core insulation:	Foam-skin-PE
Core colours:	wh/bu, wh/og, wh/gn, wh/bn
Separator:	-
Inner sheath material:	PVC
Screen over stranding element:	Al-Foil
Screen 1 over stranding:	Cu braid
Screen 2 over stranding:	-
Outer sheath material:	PVC
Outer diameter:	app. 11,6 mm
Outer sheath colour:	Black similar to RAL 9005

S/FTP 4x2xAWG 23/1 PVC/PVC

Electrical data

Characteristic impedance:	100 Ohm ± 15 Ohm at 1 to 100 MHz 100 Ohm ± 20 Ohm at 101 to 1000 MHz
Loop resistance:	160 Ohm/km max.
Mutual capacitance:	43 nF/km nom.
Rel. propagation velocity:	79 %

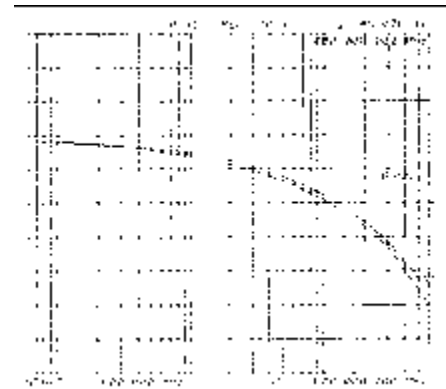

Typical values

Frequency (MHz)	10	16	62,5	100	200	300	600	900	1000
Attenuation (dB/100m)	5,6	7,1	13,9	17,5	25,2	32,1	44,9	55,0	58,0
Next (db)	100,0	100,0	96,0	94,0	88,0	84,0	73,0	71,0	69,0
ACR (db)	94,4	92,9	82,1	76,5	62,8	51,9	28,1	16,0	9,0

Technical data

Weight:	app. 153 kg/km
bending radius, repeated:	95 mm
Operating temperature range min.:	-30°C
Operating temperature range max.:	+70°C
Caloric load, approx. value:	2,62 MJ/m
Copper weight:	32,00 kg/km

Norms

Acc. to ISO/IEC 11801, Acc. to EN 50173, Acc. to EIA/TIA 568-A, Category 7e, Flame-retardant acc. to IEC 60332-1-2

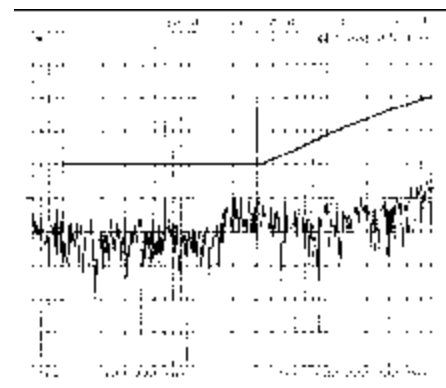

Application

HELUKAT® 600A data cables are used in the tertiary, but also in the secondary level of a network. They are characterized by large performance reserves and outstanding performance. They can be used to implement services such as Gigabit Ethernet, Fast Ethernet, Ethernet, ATM155, FDDI, token ring 4/16 Mbit/s or ISDN absolutely trouble-free. The series of HELUKAT® 600A with a double PVC jacket is constructed especially for outdoor applications like laying at house walls or in cable lines.

Part no.

801147, S/FTP 4x2xAWG 23/1 PVC/PVC (S-STP)

Dimensions and specifications may be changed without prior notice.

LAN Cable direct Burial

Category 7e

HELUKAT® 600E
S/FTP PVC

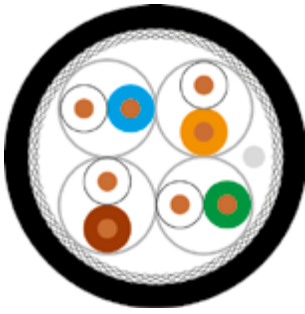

Cable structure

Inner conductor Ø:
Conductor material:
Core insulation:
Core colours:
Separator:
Screen over stranding element:
Screen 1 over stranding:
Screen 2 over stranding:
Outer sheath material:
Outer diameter:
Outer sheath colour:

S/FTP 4x2xAWG 23/1 direct burial

0,58 mm
Copper, bare
Foam-skin-PE
wh/bu, wh/og, wh/gn, wh/bn
-
Al-Foil
Cu braid
-
PVC
app. 9,8 mm
Black

Electrical data

Characteristic impedance:

Loop resistance:
Mutual capacitance:
Rel. propagation velocity:

100 Ohm ± 15 Ohm at 1 to 100 MHz
100 Ohm ± 20 Ohm at 101 to 1000 MHz
150 Ohm/km max.
42 nF/km nom.
79 %

Typical values

Frequency (MHz)	10	16	62,5	100	200	300	600	900	1000
Attenuation (dB/100m)	5,6	7,1	13,9	17,5	25,2	32,1	44,9	55,0	58,0
Next (db)	100,0	100,0	96,0	94,0	88,0	84,0	73,0	71,0	69,0
ACR (db)	94,4	92,9	82,1	76,5	62,8	51,9	28,1	16,0	9,0

Technical data

Weight: app. 102 kg/km
bending radius, repeated: 100 mm
Operating temperature range min.: -45°C
Operating temperature range max.: +65°C
Caloric load, approx. value: 1,40 MJ/m
Copper weight: 32,00 kg/km

Norms

Acc. to ISO/IEC 11801, Acc. to EN 50173, Acc. to EIA/TIA 568-A, Category 7e, Flame-retardant acc. to IEC 60332-1-2, Smoke density acc. to IEC 61034

Application

HELUKAT® 600E data cables are used in the tertiary, but also in the secondary level of a network. They are characterized by large performance reserves and outstanding performance. They can be used to implement services such as Gigabit Ethernet, Fast Ethernet, Ethernet, ATM155, FDDI, token ring 4/16 Mbit/s or ISDN absolutely trouble-free. The series of HELUKAT® 600E with a cold resistant PVC jacket is constructed especially for outdoor applications like laying at house walls or direct burial.

Part no.

802167, S/FTP 4x2xAWG23/1 PVC (S-STP)

Dimensions and specifications may be changed without prior notice.

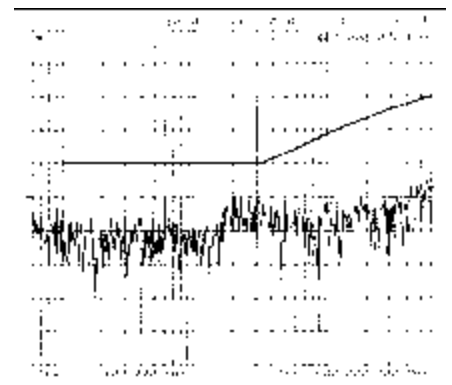
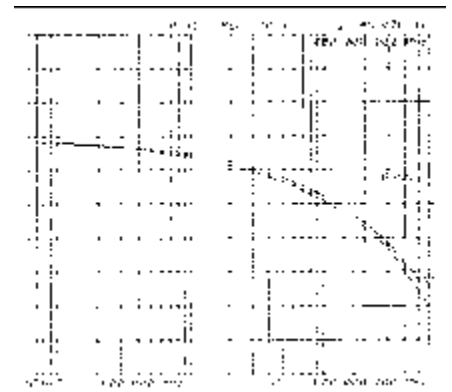

BUS Cables

Profibus L2 direct Burial without + with Armouring



PE

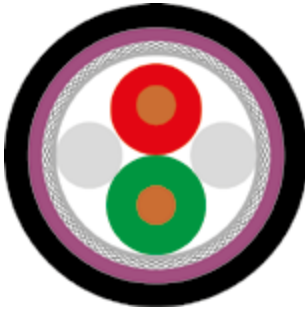

Type Cable structure

Inner conductor diameter:
Core insulation:
Core colours:
Stranding element:
Separator:
Inner sheath material:
Shielding 1:
Total shielding:
Armouring:
Outer sheath material:
Cable external diameter:
Outer sheath colour:

Direct burial 1x2x0.64 mm

Copper, bare (AWG 22/1)
Foam-skin-PE
rd, gn
2 cores + 2 fillers stranded together
Polyester foil over stranded bundle
PVC
Al-Foil
Cu braid, tinned
-
PE
app. 10,0 mm ± 0,2 mm
Black similar to RAL 9005

Direct burial 1x2x0.64 mm

Copper, bare (AWG 22/1)
Cell PE
rd, gn
2 cores + 2 fillers stranded together
-
PVC
Al-Foil
Cu braid, tinned
Steel band
PE
app. 10,6 mm ± 0,5 mm
Black similar to RAL 9005

Electrical data

Characteristic impedance:
Conductor resistance, max.:
Insulation resistance, min.:
Loop resistance:
Mutual capacitance:
Nominal voltage:
Test voltage:
Attenuation:

150 Ohm ± 10 %
55 Ohm/km
1 GOhm x km
110 Ohm/km max.
30 nF/km nom.
-
1,5 kV
9,6 kHz < 2,5 dB/km
38,4 kHz < 4,0 dB/km
3 MHz < 22,0 dB/km
20 MHz < 42,0 dB/km

150 Ohm ± 10 %
55 Ohm/km
5 GOhm x km
110 Ohm/km max.
30 nF/km nom.
250 V
1,5 kV
9,6 kHz < 2,5 dB/km
38,4 kHz < 4,0 dB/km
4 MHz < 22,0 dB/km
16 MHz < 42,0 dB/km

Technical data

Weight:
bending radius, repeated:
Operating temperature range min.:
Operating temperature range max.:
Caloric load, approx. value:
Copper weight:

app. 92 kg/km
150 mm
-40°C
+80°C
2,657 MJ/m
24,00 kg/km

app. 132 kg/km
165 mm
-40°C
+80°C
2,40 MJ/m
24,00 kg/km

Norms

Applicable standards:

Profibus acc. to DIN 19245 T3 and EN50170

Profibus acc. to DIN 19245 T3 and EN50170

Application

HELUKABEL® Profibus L2 Direct Burial cables without + with armouring are special cables in the Profibus industrial networks. The version without armouring is for normal and direct cable burial in the ground. The version with steel tape armouring offers additional protection against rodents and is the right choice for regions with such animals.

Part no.

82824, Profibus ERD

802177, Profibus L2

Dimensions and specifications may be changed without prior notice.

BUS Cables

CAN Bus direct Burial



PE

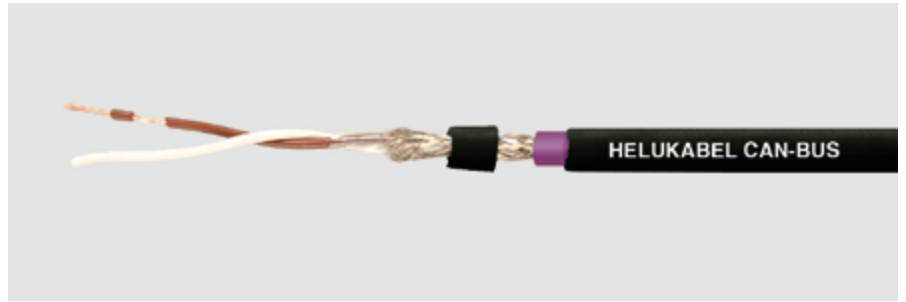
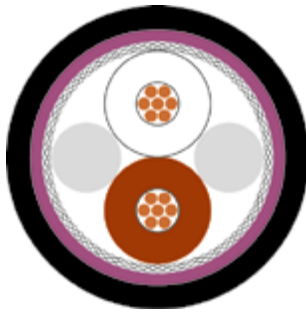

Type

Cable structure

Inner conductor diameter:
Core insulation:
Core colours:
Stranding element:
Separator:
Inner sheath material:
Shielding 1:
Total shielding:
Armouring:
Outer sheath material:
Cable external diameter:
Outer sheath colour:

Direct burial

1x2x0.50 mm² (stranded)

Copper, bare (AWG 20/7)
Foam-skin-PE
wh/bn
2 cores + 2 fillers stranded together
Polyester foil over stranded bundle
PVC
-
Cu braid, tinned
PET/PA tape
PE
app. 9,2 mm ± 0,4 mm
Black similar to RAL 9005

Direct burial

4x1x0.50 mm² (stranded)

Copper, bare (AWG 20/7)
Foam-skin-PE
wh, bn, gn, ye
Star quad
Polyester foil over stranded bundle
PVC
-
Cu braid, tinned
PET/PA tape
PE
app. 9,7 mm ± 0,4 mm
Black similar to RAL 9005

Electrical data

Characteristic impedance:
Conductor resistance, max.:
Insulation resistance, min.:
Loop resistance:
Mutual capacitance:
Test voltage:

120 Ohm ± 10 %
37 Ohm/km
1 GOhm x km
74 Ohm/km max.
40 nF/km nom.
1,5 kV

120 Ohm ± 10 %
36,4 Ohm/km
1 GOhm x km
72,8 Ohm/km max.
44 nF/km nom.
1,5 kV

Technical data

Weight:
bending radius, repeated:
Operating temperature range min.:
Operating temperature range max.:
Caloric load, approx. value:
Copper weight:

app. 105 kg/km
150 mm
-40°C
+70°C
2,05 MJ/m
33,00 kg/km

app. 115 kg/km
160 mm
-40°C
+70°C
2,18 MJ/m
45,00 kg/km

Norms

Applicable standards:

CAN Bus acc. to ISO 11898-2

CAN Bus acc. to ISO 11898-2

Application

HELUKABEL® CAN Bus Direct Burial is suitable for fixed outdoor installation or direct burial applications. The 2-pair version is designed with star-quad twisting, i.e. diagonal conductors form an electrical pair and meets the requirements of the CAN standard. For cable lengths up to 600m (observe CAN specifications).

Part no.

804268, CAN BUS

804269, CAN BUS

Dimensions and specifications may be changed without prior notice.

Wallbox: Wall Charging Station for Electric Cars

AC CHARGING STATION WITH HIGH PERFORMANCE AND CONVENIENCE

Compact, efficient and quickly installed — the so-called wallbox, a wall charging station, offers a convenient way to charge electric cars. It can be installed in a few simple steps, whether on the wall of your own home

or in single and multi-storey car parks. The AC charging station offers users the highest level of convenience as well as a reliable charging performance thanks to its fixed installation.

Wallbox

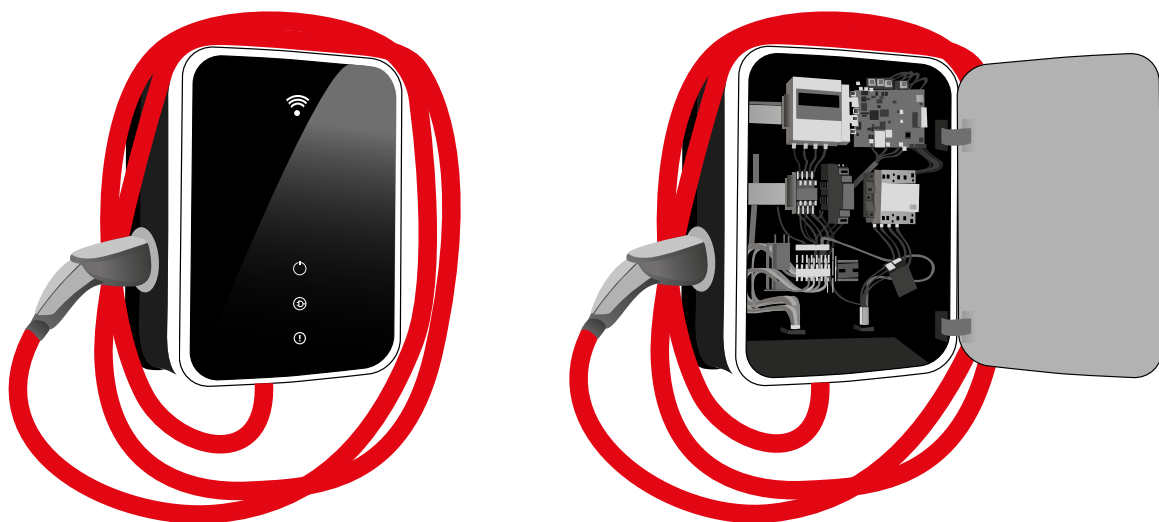

THESE DATA CABLES/PATCH CABLES HAVE AN INCREASED DIELECTRIC STRENGTH OF 4/6 KV:

Type	Cable	Plugs
Patch cable Industrial Ethernet	SF/UTP 4x2xAWG26/7	RJ45 plug TM21, double sided 180°
Patch cable Industrial Ethernet	SF/FTP 4x2xAWG26/7	RJ45 plug, double sided 180°
HELUKABEL® USB BUS S 2.0	1x2xAWG28 + 1x2xAWG20, shielded, PUR	USB Type A 30 μ, gold-plated, straight overmoulded USB Type B 30 μ, gold-plated, straight overmoulded

Patch Cables Industrial Ethernet

200IND PUR, RJ45 plug TM21 both sides 180°



SF/UTP, Category 5e

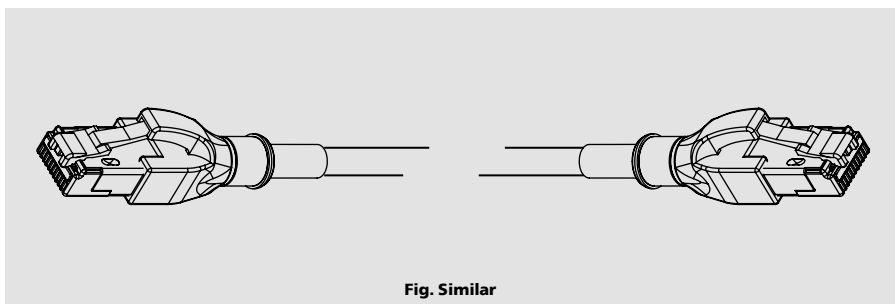

Type

Patch cable 200IND SF/UTP 4x2xAWG26/7 Cat 5e PUR grey RJ45 plug TM21 both sides 180°

Cable

Designation:	SF/UTP 4x2xAWG26/7
Category (Cable):	5e
Conductor:	bare stranded copper AWG 26/7
Sheath material:	PUR halogen free and flame retardant, nom. 5.8 mm Ø
Sheath colour:	grey similar RAL 7035
Bending radius:	min. 46 mm multiple / min. 29 mm once
Temp.-range:	-40°C to +80°C fixed installation / -30°C to +80°C flexing
Conductor resistance:	max. 130 Ohm/km
Insulation resistance:	5 GOhm x km
Cable weight:	approx. 44 kg/km

Plug

Category (Plug):	5e
Data rate:	up to 1 Gbit
Frequency range:	up to 100 MHz
Connector both sides:	RJ45 8-pole Hirose TM21 Cat 6
Anti-kink sleeve:	mounted with locking lever protection (alternatively with overmolded connector possible)
Pin pos.:	1:1
Coding:	TIA/EIA 568B
Mating cycles:	max. 750

Flame proof

acc. to IEC 60332-1-2

Norms and standards

RoHS conform, category 5e, silicone free, halogen free

Application

HELUKAT® 200IND patch cable for flexible use with robust PUR sheath.
The cable by meter art. 800068 is with UL approval AWM Style 21576 80°C 1000V.
In addition, the sheath is tested for 6 kV AC for 60 seconds (type test).

Preferred types

Length in meters	0.15	0.25	0.5	1.0	1.5	2.0	3.0	5.0	7.5	10.0	15.0
------------------	------	------	-----	-----	-----	-----	-----	-----	-----	------	------

Dimensions and specifications may be changed without prior notice

Patch Cables Industrial Ethernet

EXTRAFLEX 10 Gbit, RJ45 plug both sides 180°



SF/FTP, Category 6_A

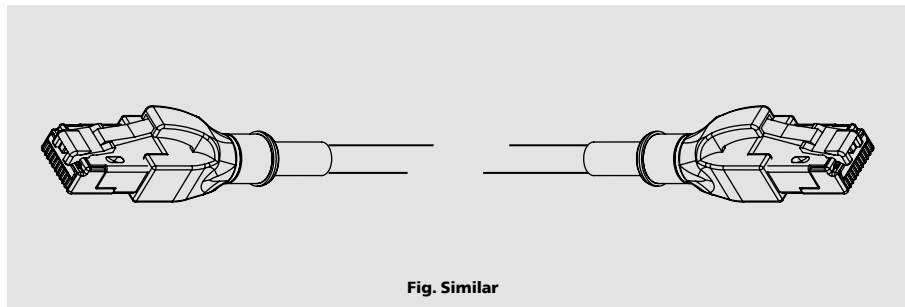

Type

**Extraflex Patch Cable 10 Gbit, SF/FTP 4x2xAWG26/7
Cat 6_A TPE green, RJ45 plug both sides 180°**

Cable

Designation:	SF/FTP 4x2xAWG26/7
Category (Cable):	7
Conductor:	bare stranded copper AWG 26/7
Sheath material:	TPE compound halogen free and flame retardent, nom. 6.5 mm Ø
Sheath colour:	green similar RAL 6018
Bending radius:	min. 5 x d (cable outerdiameter maximum)
Temp.-range:	-20°C to +75°C
Conductor resistance:	nom. 142 Ohm/km
Insulation resistance:	100 MOhm x km
Cable weight:	approx. 44 kg/km

Plug

Category (Plug):	6 _A
Data rate:	up to 10 Gbit
Frequency range:	up to 500 MHz
Connector both sides:	RJ45 8-pole acc. to IEC 60603-7-51, contacts 50 µ gold plated, screened overmolded with locking lever protection
Anti-kink sleeve:	
Pin pos.:	1:1x
Coding:	TIA/EIA 568B
Mating cycles:	max. 750

Flame proof

acc. to IEC 60332-1-2

Halogen free

acc. to IEC 60754-2

Norms and standards

RoHS conform, category 5e, Low smoke acc. to IEC 61034, silicone free

Application

Extraflex Patch cable for highly flexible application with TPE sheath. This series has been tested in swivel bending as well as roller bending and torsion tests and offers excellent properties compared to conventional patch cables with PVC or FRNC sheath.

Preferred types

Part.-No.	11007747	11007748	11007749	11007750	11007751	11007752	11007753	11007754	11007755	11007756	11007757
Length in meters	0.15	0.25	0.5	1.0	1.5	2.0	3.0	5.0	7.5	10.0	15.0

Dimensions and specifications may be changed without prior notice

HELUKABEL® USB BUS S 2.0

Plug type A + B



USB BUS S 2.0

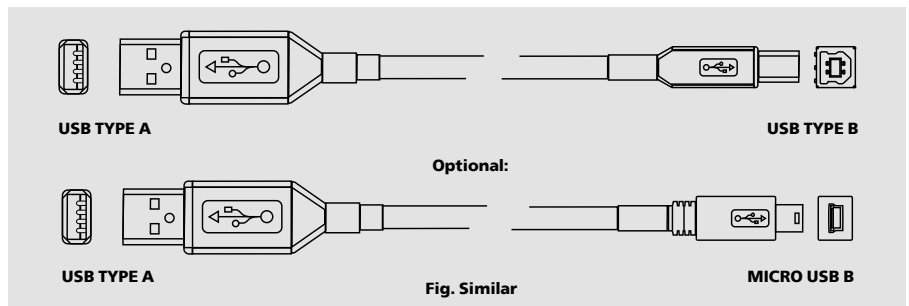

Type

USB BUS S 2.0: 1x2xAWG28 + 1x2xAWG20 PUR violet side 1 type A / side 2 type B, both straight overmolded

Cable

Designation:	1x2xAWG28 + 1x2xAWG20 screened PUR
USB (Cable):	2.0
Conductor:	tinned copper AWG 28/19 (data pair) tinned copper AWG 20/19 (power cores)
Screening:	plastic laminated aluminium foil + tinned copper braid
Sheath material:	PUR halogen free and flame retardent, nom. 5.0 mm Ø
Sheath colour:	violet
Bending radius:	min. 52mm in drag chain / 39mm multiple / min. 26mm once
Temp.-range:	-40°C to +80°C fixed installation / -30°C to +60°C flexing
Conductor resistance:	max. 230 ohm / km (AWG 28) / max. 36.7 ohm / km (AWG 20)
Insulation resistance:	1 GOhm x km
Cable weight:	approx. 45 kg/km

Plug

USB standard:	2.0
Connector side 1:	USB type A 30 µ gold plated straight overmolded
Connector side 2:	USB type B 30 µ gold plated straight overmolded
Mating cycles:	min. 10.000

Flame proof

acc. to IEC 60332-1-2 and UL 1581 §1060 – 1090 standard requirements

Oil-resistant

acc. to IEC 60811-2-1, ASTM oil 1

Norms and standards

silicone free, halogen free, RoHS conform

Application

HELUKABEL® USB BUS S with PUR sheath is drag chain quality as harnessed product and on both sides gold plated USB connectors. The cable by meter art. 802469 is with UL approval AWM Style 20963 80°C 30V. **In addition, the sheath is tested for 4 kV AC for 60 seconds (type test).**

Preferred types

Length in meters	0.5	1.0	1.5	2.0	3.0	5.0
------------------	-----	-----	-----	-----	-----	-----

Dimensions and specifications may be changed without prior notice



more information
on page 78

Pre-Assembled Fibre Optic Cables

HELUCOM® pre-assembled fibre optic cables can be installed without special skills and without special tools. The cable is ready mounted and can be connected directly after insertion. The entire installation of complete fibre optic links is practically limited to the insertion. In the splitters, the fibres from the loose tube cable are routed without splicing in the individual simplex cables. The simplex cables are terminated with factory-assembled plugs. For insertion, the plugs, the simplex cables and the splitter are covered by a

plug protector supplied with the unit. The insertion aid is connected to the pull rope. In this way, the cable can be pulled in like a conventional cable with the factory-prepared splitter. The advantages of a pre-assembled cable that has been finished in the factory are obvious. The fibre optic cables are cut to any desired length and the fibres are bonded in a clean and dust-free environment with connectors of various designs.

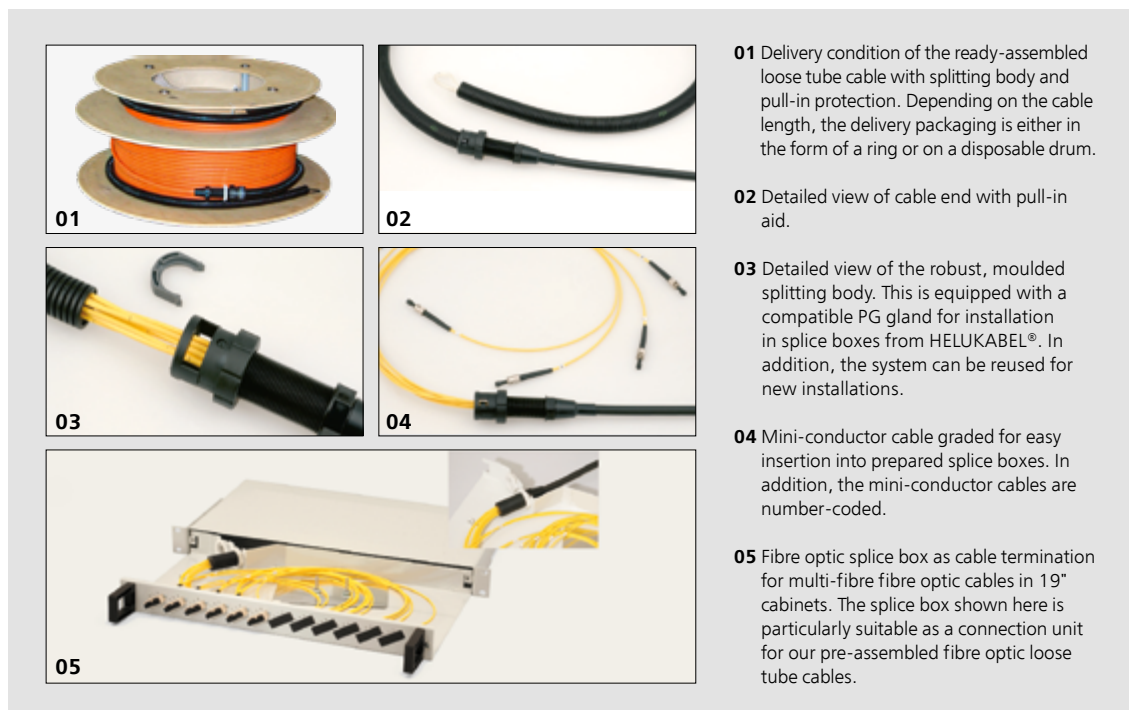

ATTRIBUTES:

Uses:

Outdoor and indoor cabling

Cable types:

- Zipcords with halogen-free outer sheath
- Breakout cable with halogen-free outer sheath
- Mini breakout cable with halogen-free outer sheath
- Fibre optic cable with central or stranded loose tubes
- Plastic Optical Fibre (POF) cable

Connector systems:

- ST, SC, SCdx, LC, MTRJ, E-2000, DIN, FDDI, FC-PC and F-SMA

Fiber types:

- E9/125 µm (G652.d, G657.A1 + A2)
- G50/125 µm (OM2, OM3, OM4)
- G62,5/125 µm (OM1)
- 200/230 µm
- 980/1000 µm

Additional fittings:

- Insertion aid / insertion tube / core coding

HELUTOP® HT

Cable gland



TECHNICAL DATA

Plastic cable gland acc. to EN62444 with vibration protection

Protection class: IP 66 / IP 68 - 5 bar, 30 min /
IP 69K acc. to DIN EN 60529

Temperature range: -20°C up to +100°C

Dimensions:
G Thread size
GL Thread length
SW Spanner size

MATERIAL

- Polyamide PA 6, V2 acc. to UL 94
- seal: Chloroprene-rubber (CR)
- phosphor-free
- silicone-free
- cadmium-free

PROPERTIES

- optimum strain relief through clamping lamella
- easy to assemble
- large clamping areas

APPLICATION

- plant and machine construction
- robot construction
- automation technology
- vehicle construction and shipbuilding
- rail technology
- installation technology
- control cabinet construction

Metric thread

Part no. light grey RAL 7035	Part no. dark grey RAL 7001	Part no. black RAL 9005	Size Metr.	Cable Ø from / to mm	Thread length mm	Spanner size mm	Unit Pcs.
93908	93923	93937	M 12 x 1.5	3.0 - 6.5	8.0	15	100
93909	93924	93938	M 16 x 1.5	4.0 - 8.0	8.0	19	50
907275	907276	907277	M 16 x 1.5	5.0 - 10.0	8.0	19	50
92667	92668	92669	M 16 x 1.5	5.0 - 10.0	10.0	22	50
93910	93925	93939	M20 x 1.5	6.0 - 12.0	10.0	24	50
93911	93926	93940	M 25 x 1.5	11.0 - 17.0	8.0	29	50
93912	93927	93941	M 32 x 1.5	15.0 - 21.0	10.0	36	25
93913	93928	93942	M 40 x 1.5	19.0 - 28.0	10.0	40	20
93914	93929	93943	M 50 x 1.5	30.0 - 38.0	18.0	60	10
93915	93930	93944	M 63 x 1.5	34.0 - 44.0	18.0	65	10

Metric thread - mit Reduziereinsatz

Part no. light grey RAL 7035	Part no. dark grey RAL 7001	Part no. black RAL 9005	Size Metr.	Cable Ø from / to mm	Thread length mm	Spanner size mm	Unit Pcs.
903532	903542	903552	M 12 x 1.5	2.0 - 5.0	8.0	15	100
903533	903543	903553	M 16 x 1.5	2.0 - 6.0	8.0	19	50
903534	903544	903554	M 20 x 1.5	5.0 - 9.0	10.0	24	50
903535	903545	903555	M 25 x 1.5	9.0 - 13.0	8.0	29	50
903536	903546	903556	M 32 x 1.5	11.0 - 15.0	10.0	36	25
903537	903547	903557	M 40 x 1.5	16.0 - 23.0	10.0	46	20
903538	903548	903558	M 50 x 1.5	25.0 - 31.0	18.0	60	10
903539	903549	903559	M 63 x 1.5	29.0 - 35.0	18.0	65	10

HELUTOP® HT

Cable gland



PG thread

Part no. light grey RAL 7035	Part no. dark grey RAL 7001	Part no. black RAL 9005	Size PG	Cable Ø from / to mm	Thread length mm	Spanner size mm	VPE Pcs.
99300	99310	99320	7	3.0 - 6.5	8.0	15	100
99301	99311	99321	9	4.0 - 8.0	8.0	19	50
99302	99312	99322	11	5.0 - 10.0	8.0	22	50
99303	99313	99323	13.5	6.0 - 12.0	9.0	24	50
99304	99314	99324	16	10.0 - 14.0	10.0	27	50
99305	99315	99325	21	13.0 - 18.0	11.0	33	25
99306	99316	99326	29	18.0 - 25.0	11.0	42	20
99307	99317	99327	36	22.0 - 32.0	13.0	53	10
99308	99318	99328	42	30.0 - 38.0	13.0	60	10
99309	99319	99329	48	34.0 - 44.0	14.0	65	10

NPT thread

Part no. light grey RAL 7035	Part no. dark grey RAL 7001	Part no. black RAL 9005	Size BSP	Cable Ø from / to mm	Thread length mm	Spanner size mm	VPE Pcs.
92780	92790	92800	3/8"	5.0 - 10.0	15.0	22	50
92781	92791	92801	1/2"	6.0 - 12.0	15.0	24	50
92782	92792	92802	1/2"	10.0 - 14.0	15.0	27	50
92783	92793	92803	3/4"	13.0 - 18.0	15.0	33	25
92784	92794	92804	1"	18.0 - 25.0	18.0	42	20



more information
on page 78

HELUTOP® HT-MS

Cable gland



TECHNICAL DATA

Nickel-coated brass cable gland acc. to EN62444.

Protection class:	IP 66 / 68 - 5 bar, 30 min / IP 69K
Temperature range:	-20°C up to +100°C
Temperature range temporary:	-40°C up to +150°C
Dimensions:	G Thread size
	GL Thread length
	SW Spanner size

MATERIAL

- brass, nickel plated
- clamp: Polyamide PA 6
- seal: Chloroprene-rubber (CR)
- o-ring: NBR

PROPERTIES

- optimum strain relief through clamping plates
- easy to assemble
- large clamping areas

APPLICATION

- plant and machine construction
- robot construction
- automation technology
- vehicle construction and shipbuilding
- rail technology
- installation technology
- control cabinet construction

NOTE

- Brass surcharge will be charged for these items. Basis is 150 € / 100 kg. For more details please refer to the

metric thread

Part no.	Size Metr.	Cable Ø from / to mm	Thread length mm	Spanner size mm	Unit Pcs.
90760	M 12 x 1.5	3.0 - 6.5	6.0	14	50
99960	M 16 x 1.5	5.0 - 10.0	7.0	20	50
90762	M 20 x 1.5	6.0 - 12.0	8.0	22	50
99961	M 25 x 1.5	11.0 - 17.0	8.0	27	25
94624	M 32 x 1.5	15.0 - 21.0	9.0	34	20
99962	M 40 x 1.5	19.0 - 28.0	9.0	43	5
99963	M 50 x 1.5	27.0 - 38.0	10.0	58	5
90767	M 63 x 1.5	34.0 - 44.0	10.0	64/68	5
906199	M 63 x 1.5	44.0 - 55.0	10.0	75	5

metric thread - with reducing seal

Part no.	Size Metr.	Cable Ø from / to mm	Thread length mm	Spanner size mm	Unit Pcs.
903560	M 12 x 1.5	2.0 - 5.0	6.0	14	50
903561	M 16 x 1.5	2.0 - 6.0	7.0	17/18	50
903562	M 20 x 1.5	5.0 - 9.0	8.0	22	50
903563	M 25 x 1.5	7.0 - 12.0	8.0	24/27	25
903564	M 32 x 1.5	9.0 - 16.0	9.0	30/34	20
903565	M 40 x 1.5	12.0 - 20.0	9.0	40/43	5
903566	M 50 x 1.5	20.0 - 26.0	10.0	50/55	5
903567	M 63 x 1.5	29.0 - 35.0	14.0	64/68	5

HELUTOP® HT-MS

Cable gland



PG thread

Part no.	Size PG	Cable Ø from / to mm	Thread length mm	Spanner size mm	Unit Pcs.
90750	7	3.0 - 6.5	6.0	14	50
90751	9	4.0 - 8.0	6.0	17	50
90752	11	5.0 - 10.0	6.0	20	50
90753	13.5	6.0 - 12.0	6.5	22	50
90754	16	10.0 - 14.0	6.5	24	25
90755	21	13.0 - 18.0	7.2	30	25
90756	29	18.0 - 25.0	8.0	40	20
90757	36	30.0 - 32.0	9.0	50	5
90758	42	30.0 - 38.0	12.0	58	5
90759	48	34.0 - 44.0	14.0	64	5

NPT thread

Part no.	Size BSP	Cable Ø from / to mm	Thread length mm	Spanner size mm	Unit Pcs.
99965	3/8"	4.0 - 8.0	11.5	17/19	50
99966	1/2"	6.0 - 12.0	13.0	22	50
99967	3/4"	13.0 - 18.0	13.0	30	25
99968	1"	18.0 - 25.0	13.0	40/43	10

EMC glands
for charging station

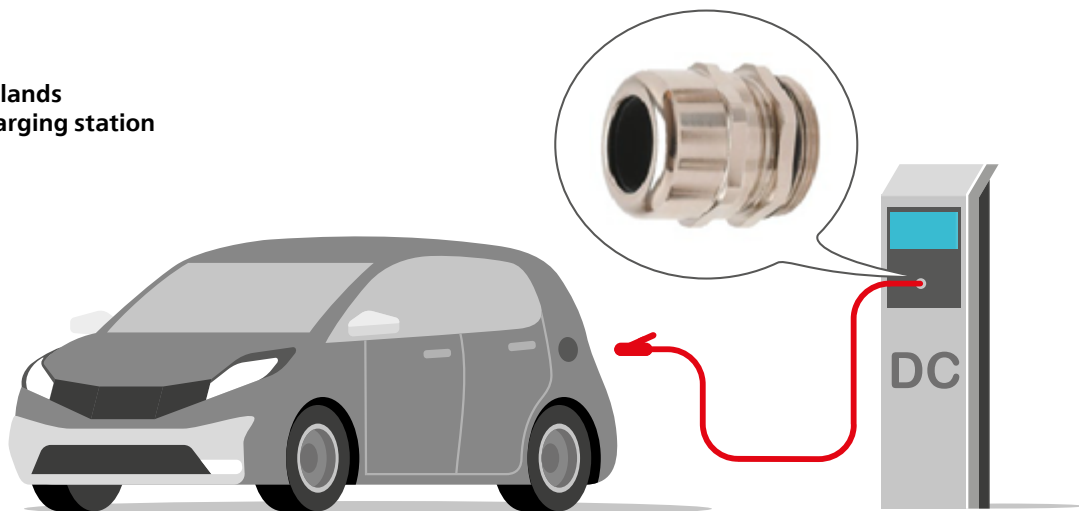

HELUTOP® MS-EP4

EMC cable gland



TECHNICAL DATA

EMC- cable gland acc. to EN 62444 with integrated contact system.

Protection class:	IP 68 - 5 bar, 30 min
Temperature range:	-20°C to +100°C
Contact system:	patented
Dimensions:	G Thread size
	GL Thread length
	SW Spanner size

MATERIAL

- brass, nickel plated
- contact system: Copper-Beryllium
- clamp: Polyamide PA 6
- seal: Chloroprene-rubber (CR)
- o-ring: NBR

PROPERTIES

- easy installation
- secure contact
- high vibration resistance

APPLICATION

- plant and machine construction
- robot construction
- automation technology
- vehicle construction and shipbuilding
- rail technology
- installation technology
- control cabinet construction

NOTE

- Brass surcharge will be charged for these items. Basis is 150 € / 100 kg. For more details please refer to the general terms and conditions.

metric thread

Part no.	Size Metr.	Cable Ø from / to mm	Thread length mm	Spanner size mm	Unit pcs.
905181	M 12 x 1.5	3.0 - 6.5	6.0	14	50
905182	M 16 x 1.5	5.0 - 10.0	6.0	20	50
905183*	M 20 x 1.5	6.0 - 12.0	6.0	22	50
905184	M 20 x 1.5	7.5 - 14.0	8.0	24/26	50
905185	M 25 x 1.5	10.0 - 18.0	8.0	30	25
905186	M 32 x 1.5	16.0 - 25.0	9.0	40	10
905187	M 40 x 1.5	22.0 - 32.0	9.0	50	5
905188	M 50 x 1.5	30.0 - 38.0	9.0	58	5
905189	M 63 x 1.5	34.0 - 44.0	14.0	64/68	5
905248*	M 63 x 1.5	37.0 - 53.0	10.0	75	5

* no CSA at 905183 and 905248.

SD-XXL

Cable gland for particularly large cable diameters



TECHNICAL DATA

The finish, similar to that of an incision sealingring, guarantees very large clamping areas.

Protection class: IP 68 - 5 bar, 30 min

Temperature range: -40°C to +100°C

Dimensions: G Thread size
GL Thread length
SW Spanner size

MATERIAL

- brass, nickel plated
- seal: NBR
- o-ring: NBR

PROPERTIES

- large-area cable sealing
- easy to assemble
- large clamping range

APPLICATION

- plant and machine construction
- automation technology
- vehicle construction and shipbuilding
- installation technology

NOTE

- BSP variant: without O-ring on connection thread, sealing insert made of TPE. A brass surcharge is charged for these items. Basis is 150 €/ 100 kg. For more details, please refer to the general terms and conditions.

metric thread

Part no.	Size Metr.	Cable Ø from / to mm	Thread length mm	Spanner size mm	Unit pcs.
905570	M 72 x 2.0	56.0 - 61.0	16.0	77	1
905506	M 75 x 1.5	56.0 - 61.0	16.0	77	1
905571	M 75 x 2.0	56.0 - 61.0	16.0	77	1
905573	M 80 x 2.0	50.0 - 56.0	18.0	90	1
905572	M 80 x 2.0	60.0 - 66.0	18.0	90	1
905575	M 85 x 2.0	63.0 - 70.0	22.0	96	1
905574	M 85 x 2.0	68.0 - 76.0	22.0	96	1
905576	M 90 x 2.0	68.0 - 76.0	22.0	98 / 96	1
905577	M 110 x 2.0	75.0 - 82.0	25.0	125 / 110	1
905578	M 120 x 2.0	88.0 - 95.0	25.0	120 / 116	1

BSP-thread

Part no.	Size BSP	Cable Ø from / to mm	Thread length mm	Spanner size mm	Unit pcs.
90604	G 3"	58.0 - 65.0	18.0	100	1
90605	G 3"	63.0 - 70.0	18.0	100	1
90606	G 4"	68.0 - 75.0	22.0	125	1
90607	G 4"	73.0 - 80.0	22.0	125	1
90608	G 4"	78.0 - 85.0	22.0	125	1
90609	G 4"	83.0 - 90.0	22.0	125	1
93440	G 5"	91.0 - 97.0	22.0	150	1
93441	G 5"	97.0 - 104.0	22.0	150	1
93442	G 5"	102.0 - 109.0	22.0	150	1
93443	G 5"	109.0 - 116.0	22.0	150	1

HELUcond PP-MOD-FPPS-O

Orange corrugated tube for protection and marking of cables



TECHNICAL DATA

Orange corrugated tube for protection and marking of cables

Temperature range: -40°C to +105°C
Temperature range temporary: up to +150°C (500h)
up to +165°C (100h)
Filling ratio: max. 70%

- non flame propagating
- halogen free
- cadmium free
- resistant to: UV radiation
- resistant to the accelerated weathering test

MATERIAL

- PP MOD BS orange similar RAL 2003

PROPERTIES

- flammability acc. to UL94: V2
- low smoke gas development
- good mechanical properties
- self-extinguishing

APPLICATION

Suitable for applications where cables or wires need to be protected and specially or separately marked.

NOTE

- suitable hose glands and hose holders on request
- test at nominal size 17:
Impact strength: 23°C: 6 Joule
Impact strength: -25°C: 2 Joule
Peak load value: 125 N
Pull out strength: 23°C: 500 N

Part no.	Type	Nominal size mm	Size for fitting cable gland	Profil	Inner Ø mm	Outer Ø mm	Bending radius stat. R. mm	Bending radius dyn. R. mm	Unit m
11019845	FPPSF-07O2.50	7	10	F	6.6	10.0	15	40	50
11019846	FPPSF-10O2.50	10	12	F	9.8	12.8	20	45	50
11019847	FPPSF-12O2.50	12	16	F	12.3	15.7	25	65	50
11019848	FPPSF-17O2.50	17	20	F	16.6	21.1	30	70	50
11019849	FPPSF-23O2.50	23	25	F	23.1	28.4	35	90	50
11019850	FPPSF-29O2.50	29	32	F	28.9	34.5	45	110	50
11019851	FPPSF-36O2.25	36	40	F	36.5	42.4	60	170	25
11019852	FPPSF-48O2.25	48	50	F	47.5	54.4	70	185	25

HELUcond PP-MOD-2PPS-O

Orange dividable corrugated tube for protection and marking of cables



TECHNICAL DATA

Orange dividable corrugated tube for protection and marking of cables

Temperature range: -40°C to +105°C
Filling ratio: max. 70%

MATERIAL

- PP MOD BS orange similar RAL 2003

PROPERTIES

- flammability acc. to UL94: V2
- low smoke gas development
- good mechanical properties
- self-extinguishing
- non flame propagating

- halogen free
- cadmium free
- resistant to: UV radiation
- resistant to the accelerated weathering test

APPLICATION

Ideal solution for retrofit application of cable protection, also pre-assembled cable harnesses with already installed connectors. The double shell conduit properly overlaps and provides enhanced cable protection capabilities against external influences and impacts. This dividable conduit type made of high grade specially modified Polypropylene is suitable for applications in which cables or pipelines have to be marked separately.

NOTE

- suitable hose glands and hose holders on request
- test at nominal size 17:
Peak load value: 320 N

Part no.	Type	Nominal size mm	Profile	Inner Ø mm	Outer Ø mm	Bending radius stat. R. mm	Unit m
11019853	2PPSM-07O2.50	07	M	6.3	10.0	20	50
11019854	2PPSM-10O2.50	10	M	8.4	13.4	25	50
11019855	2PPSM-11O2.50	11	M	11.0	16.1	30	50
11019856	2PPSM-14O2.50	14	M	12.5	18.5	35	50
11019857	2PPSM-16O2.50	16	M	16.0	21.5	40	50
11019858	2PPSM-20O2.50	20	M	19.2	25.3	45	50
11019859	2PPSM-23O2.50	23	M	23.4	30.8	50	50
11019860	2PPSM-29O2.25	29	M	27.3	35.5	90	25
11019861	2PPSM-37O2.25	37	M	31.0	41.4	110	25
11019862	2PPSM-45O2.25	45	M	42.7	54.0	130	25
11019863	2PPSM-70O2.10	70	M	67.5	79.8	190	10
11019864	2PPSM-100O2.10	100	M	87.5	102.5	210	10

Glossary

You can find further information in our Download Centre:
www.helukabel.com/download-center

ONLINE TO BROWSE THROUGH
OR DOWNLOAD



**NORTH AMERICAN
CABLES & ACCESSORIES**

CATALOGUE
EDITION 2

ONLINE TO BROWSE THROUGH
OR DOWNLOAD



CABLE ACCESSORIES

CATALOGUE
ISSUE 21

ONLINE TO BROWSE THROUGH
OR DOWNLOAD



**ALUMINIUM CABLE &
-WIRES**

CATALOGUE

ONLINE TO BROWSE THROUGH
OR DOWNLOAD



**CABLE SYSTEMS FOR
ENERGY SUPPLY &
TELECOMMUNICATION**

FLYER

ONLINE TO BROWSE THROUGH
OR DOWNLOAD



**DATA, NETWORK &
BUS TECHNOLOGY**

CATALOGUE
ISSUE 12

ONLINE TO BROWSE THROUGH
OR DOWNLOAD



**HELUPOWER®
REFLECT**

FLYER



POWERLINE

WK

Request Spiral Cables

Charging cables HELUPOWER® Charge 750 AC

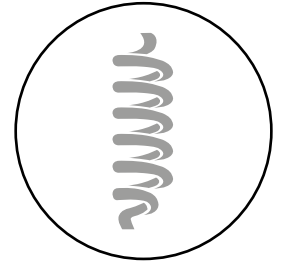

You can also download this form online at:
www.helukabel.com/request-spiral-cables

Tel: +49 (0)7150 9209-135 • Fax: +49 (0)7150 9209-5135

E-mail: joachim.koch@helukabel.de

Customer: _____

Customer no.: _____

Date: _____

Demand (pcs.): _____

Annual demand (pcs.): _____

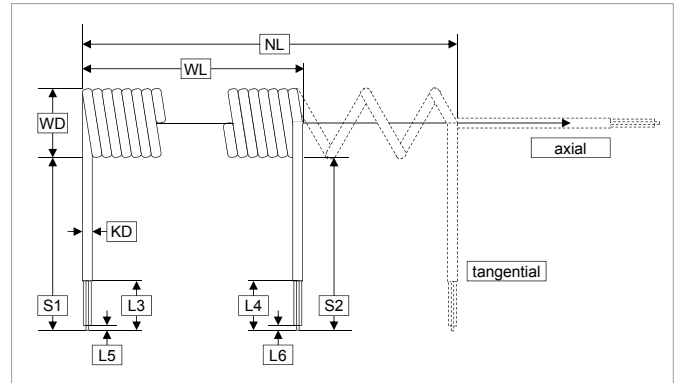

Number of cores x cross-section:

- 3G2.5+1x0.5mm²
 5G2.5+1x0.5 mm²
 3G6+1x0.5mm²
 5G6+1x0.5mm²
 other dimensions

Sheath colour:

- black
 red
 other colours _____

Effective length (NL): spiral extended (spiral contracted WL *) _____

- 2m (500mm*)
 3m (600mm*)
 4m (700mm*)
 5m (800mm*)
 7m (1300mm*)
 desired length _____ m

Spiral outside diameter (WD) (50-100mm) _____ mm

- End S1 axial tangential length _____ mm
 End S2 axial tangential length _____ mm

Notes

Request Reeling Cables

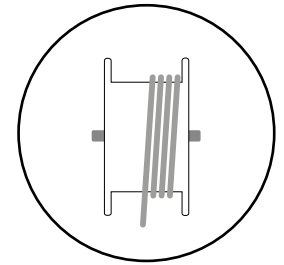

You can also download this form online at:

www.helukabel.com/request-reeling-cables

Company _____

Location _____

Surname, Name _____

Maschine Type _____

Street, Nr. _____

In Operation Since _____

Postal Code, City _____

Telephone / Fax _____

E-mail _____

Sender/Stamp _____

1. Reeling configuration

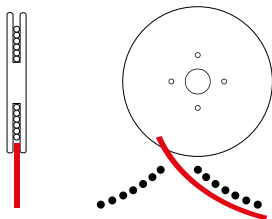

1.1 Monospiral

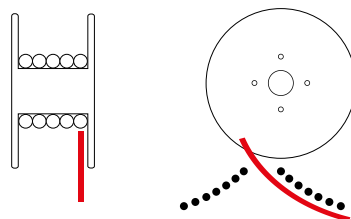

1.2 single layer (multispiral)

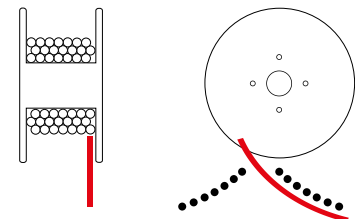

1.3 multi layer

2. Arrangement of the cable

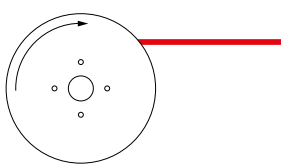

2.1 horizontal

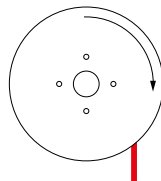

2.2 vertical

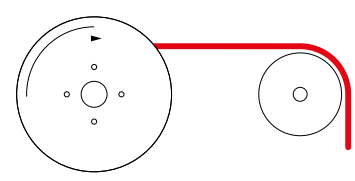

2.3 with redirection

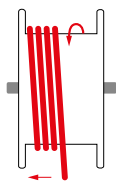

2.4 Feed

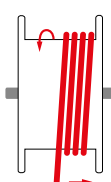

2.5 Feed

2.6 Different feed
(please attach sketch or photo)

3. Roadway end wire fixation

- 3.1 Cable grip
- 3.2 Bracket
- 3.3 Other _____

4. Movement parameters

- 4.1 Movement distance (max.) _____
- 4.2 Travel speed (m/s) _____
- 4.3 Travel acceleration (m/s²) _____
- 4.4 Cycles/Time unit _____

NOTES

Technical modifications

© HELUKABEL® GmbH Hemmingen

Dimensions and specifications may change without prior notice. Consequently all illustrations, numerical data, etc. are provided without guarantee. Colour deviations between photos and delivered goods cannot be avoided. Reproduction or duplication of the text and illustrations, in whole or in part, remain reserved. The transfer of copyrights requires the written consent of HELUKABEL® GmbH. Our General Terms of Delivery and Payment, which can be viewed at www.helukabel.com, apply.

Length markings

The length marking, which cannot be calibrated, is an aid, e.g. for easy material allowance determination or for determination of the length remaining on the drum. Deviation of the wire length shown by the marking is up to 1%. Incomplete length markings or length markings missing from sections, deviations of the cable length shown by the length marking do not substantiate any legal obligation whatsoever. Only use calibrated measurement devices to determine wire length.

Safety notice

The cables and wires described in the catalogue are produced in accordance with national and international standards, as well as plant standards; application safety, as stipulated in the safety directives, standards, and statutory regulations, as amended, are provided. Following proper installation and usage guidelines, the possibility of product-specific dangers can be excluded. This catalogue describes general information for each product's use. Independent of the above, the applicable DIN VDE specifications apply. Installation and processing must only be executed by qualified electricians.

Our General Terms of Delivery and Payment, which can be viewed at www.helukabel.com

For more information, please contact our e-Mobility product managers:



Uwe Schenk

Global Segment Manager
e-Mobility & Renewable
Energies
Tel: +49 7150-9209-624
Fax: +49 7150-9209-5624
Mobil: +49 171-6068424
uwe.schenk@helukabel.de



Joachim Koch

Special Cables
Teamleader Sales e-Mobility &
Renewable Energies
Tel: +49 7150 9209 135
Fax: +49 7150 9209 5135
Mobil: +49 173 61 62 995
joachim.koch@helukabel.de



Andreas Petasch

Special Cables
Sales e-Mobility & Renewable
Energies
Tel: +49 7150 9209 978
Fax: +49 7150 9209 5978
andreas.petasch@helukabel.de

**(Channeling
POWER)** 